



Georgia Standards of Excellence Middle School Support

Mathematics

GSE Grade 6

Connections/Support Materials for
Remediation

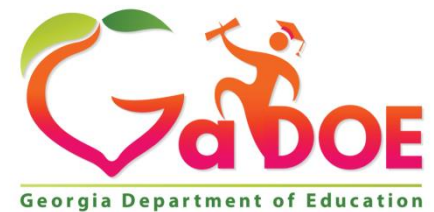

Richard Woods, Georgia's School Superintendent
"Educating Georgia's Future"

Table of Contents

OVERVIEW	4
SETTING THE ATMOSPHERE FOR SUCCESS	4
CONCEPTS/SKILLS TO MAINTAIN FROM PREVIOUS GRADES.....	5
STANDARDS FOR MATHEMATICAL CONTENT	10
ELEMENTARY REFERENCE STANDARDS.....	12
STANDARDS FOR MATHEMATICAL PRACTICE	29
SELECTED TERMS AND SYMBOLS.....	32
TABLE OF INTERVENTIONS	33
SCAFFOLDED INSTRUCTIONAL LESSONS.....	35
Building Number Sense Activities	37
Fact Families.....	48
Is It Reasonable?	59
Yummy...Chocolate – 3 Act Task	67
Quick Check	72
Birthday Cake	75
Fraction Clues	91
Multiplying Fractions	104
Birthday Cookout.....	115
Representing Powers of Ten Using Base Ten Blocks.....	121
Multiplying by Powers of Ten.....	124
Comparing Decimals	127
Integers on the Number Line	132
Translating Math	137
The Algebra of Magic	150
Orange Fizz Experiment	165
Which Is the Better Deal?	179
“Illustrative” Review 1	183
The Variable Machine	184
“Illustrative” Review 2	187
Don’t Sink My Battleship!	188
APPENDIX OF RELEASED SAMPLE ASSESSMENT ITEMS.....	193
WEB LINKS.....	201

ADDITIONAL RESOURCES 211

OVERVIEW

The tasks in this document are from the high school course Foundations of Algebra. Foundations of Algebra is a first year high school mathematics course option for students who have completed mathematics in grades 6 – 8 yet will need substantial support to bolster success in high school mathematics. The course is aimed at students who have reported low standardized test performance in prior grades and/or have demonstrated significant difficulties in previous mathematics classes.

In many cases, students enter middle school with the same mathematics difficulties that inhibit their success in algebra. Due to this, the Foundations of Algebra lessons have been sorted into collections aligned to 6th, 7th, and 8th grade mathematics standards and prerequisite skills. These tasks are suggested for use in middle school math connections/support classes and with students who are in the process of mastering the identified standards.

SETTING THE ATMOSPHERE FOR SUCCESS

“There is a huge elephant standing in most math classrooms, it is the idea that only some students can do well in mathematics. Students believe it; parents believe and teachers believe it. The myth that mathematics is a gift that some students have and some do not, is one of the most damaging ideas that pervades education in the US and that stands in the way of students’ mathematics achievement.” (Boaler, Jo. “Unlocking Children’s Mathematics Potential: 5 Research Results to Transform Mathematics Learning” youcubed at Stanford University. Web 10 May 2015.)

Some students believe that their ability to learn mathematics is a fixed trait, meaning either they are good at mathematics or not. This way of thinking is referred to as a **fixed mindset**. Other students believe that their ability to learn mathematics can develop or grow through effort and education, meaning the more they do and learn mathematics the better they will become. This way of thinking is referred to as a **growth mindset**.

In the fixed mindset, students are concerned about how they will be viewed, smart or not smart. These students do not recover well from setbacks or making mistakes and tend to “give up” or quit. In the growth mindset, students care about learning and work hard to correct and learn from their mistakes and look at these obstacles as challenges.

The manner in which students are praised greatly affects the type of mindset a student may exhibit. Praise for intelligence tends to put students in a fixed mindset, such as “You have it!” or “You are really good at mathematics”. In contrast, praise for effort tends to put students in a growth mindset, such as “You must have worked hard to get that answer.” or “You are developing mathematics skills because you are working hard”. Developing a growth mindset produces motivation, confidence and resilience that will lead to higher achievement. (Dweck, Carol. Mindset: The New Psychology of Success. Ballantine Books: 2007.)

“Educators cannot hand students confidence on a silver platter by praising their intelligence. Instead, we can help them gain the tools they need to maintain their confidence in learning by

keeping them focused on the process of achievement.” (Dweck, Carol S. “The Perils and Promises of Praise.” *ASCD*. Educational Leadership. October 2007. Web 10 May 2015.)

Teachers know that the business of coming to know students as learners is simply too important to leave to chance and that the peril of not undertaking this inquiry is not reaching a learner at all. Research suggests that this benefit may improve a student’s academic performance. Surveying students’ interests in the beginning of a year will give teachers direction in planning activities that will “get students on board”. Several interest surveys are available and two examples can be located through the following websites:

https://www.scholastic.com/content/collateral_resources/pdf/student_survey.pdf

http://www.niu.edu/eteams/pdf_s/VALUE_StudentInterestInventory.pdf

CONCEPTS/SKILLS TO MAINTAIN FROM PREVIOUS GRADES

Students are expected to have prior knowledge/experience related to the concepts and skills identified below. A pre-assessment may be necessary in order to determine if time needs to be spent on conceptual activities that help students develop a deeper understanding of these ideas.

The web links may be used as needed for additional resources aimed at intervention, and even though the interventions may be needed throughout the course, these concepts correspond to the first six 6th grade units where the needed skills first appear as prerequisites.

Unit 1

- **Develop Number Sense**

Intervention Tip: Students can use color tiles to help make sense of numbers.

<https://www.illustrativemathematics.org/content-standards/5/NBT/A/tasks/1813>

<https://www.illustrativemathematics.org/content-standards/5/NBT/A/1/tasks/1562>

<https://www.illustrativemathematics.org/content-standards/5/NBT/A/1/tasks/1931>

<https://www.illustrativemathematics.org/content-standards/5/NBT/A/1/tasks/1800>

<https://www.illustrativemathematics.org/content-standards/5/NBT/A/1/tasks/1799>

Intervention Tip: Some students may have more success starting with fewer numbers to compare.

<https://www.illustrativemathematics.org/content-standards/5/NBT/A/3/tasks/1801>

<https://www.illustrativemathematics.org/content-standards/5/NBT/A/4/tasks/1804>

<https://www.illustrativemathematics.org/content-standards/5/NBT/A/3/tasks/1802>

<https://www.illustrativemathematics.org/content-standards/5/NBT/A/3/tasks/1803>

<https://www.illustrativemathematics.org/content-standards/tasks/1808>

<https://www.illustrativemathematics.org/content-standards/5/NBT/A/4/tasks/1804>

<https://www.illustrativemathematics.org/content-standards/tasks/1805>

<https://www.illustrativemathematics.org/content-standards/tasks/1806>

<https://www.illustrativemathematics.org/content-standards/tasks/1807>

<https://www.illustrativemathematics.org/content-standards/tasks/1683>

- **Compute with Multi-digit Whole Numbers and Decimals (to hundredths), Including Application of Order of Operations**

<https://www.illustrativemathematics.org/content-standards/tasks/1989>
<https://www.illustrativemathematics.org/content-standards/tasks/1851>
<https://www.illustrativemathematics.org/content-standards/5/NBT/B/5/tasks/1812>
<https://www.illustrativemathematics.org/content-standards/tasks/1821>
<https://nzmaths.co.nz/resource/multiplication-madness>
<https://www.illustrativemathematics.org/content-standards/5/NBT/B/7/tasks/292>
<https://www.illustrativemathematics.org/content-standards/4/NBT/B/6/tasks/1774>
<https://nzmaths.co.nz/resource/bowl-fact>
<https://www.illustrativemathematics.org/content-standards/5/NBT/B/6/tasks/878>
<https://www.illustrativemathematics.org/content-standards/5/NBT/B/7/tasks/1293>
<https://www.illustrativemathematics.org/content-standards/tasks/2196>
<https://www.illustrativemathematics.org/content-standards/tasks/2197>
<https://www.illustrativemathematics.org/content-standards/5/NBT/A/2/tasks/1524>
<https://www.illustrativemathematics.org/content-standards/tasks/1596>
<https://nzmaths.co.nz/resource/order-operations-0>

Article: <https://ccgpsmathematicsk-5.wikispaces.com/file/view/Order%20of%20Operations%20The%20Myth%20and%20The%20Math.pdf/586317763/Order%20of%20Operations%20The%20Myth%20and%20The%20Math.pdf>

- **Compute using Addition, Subtraction, Multiplication, and Division of Common Fractions**

Intervention Tip: Students can create their own word problems using fractions. If students struggle to generate word problems from scratch, provide the context for them and have them provide the question that can be asked to match the context. For example, with the first set of numbers, “*Johnny has $1\frac{3}{4}$ cups of cupcake batter. Each cupcake needs $\frac{1}{2}$ of a cup of batter.*” What could be the question?

<https://www.illustrativemathematics.org/content-standards/5/NF/A/1/tasks/839>
<https://www.illustrativemathematics.org/content-standards/5/NF/A/1/tasks/848>
<https://www.illustrativemathematics.org/content-standards/5/NF/A/1/tasks/859>
<https://www.illustrativemathematics.org/content-standards/5/NF/A/1/tasks/1563>
<https://www.illustrativemathematics.org/content-standards/5/NF/A/1/tasks/855>
<https://www.illustrativemathematics.org/content-standards/5/NF/A/1/tasks/861>
<https://www.illustrativemathematics.org/content-standards/5/NF/A/1/tasks/847>
<https://www.illustrativemathematics.org/content-standards/5/NF/A/2/tasks/481>
<https://www.illustrativemathematics.org/content-standards/5/NF/A/tasks/609>
<https://www.illustrativemathematics.org/content-standards/5/NF/A/tasks/2077>
<https://www.illustrativemathematics.org/content-standards/5/NF/B/tasks/882>
<https://www.illustrativemathematics.org/content-standards/5/NF/B/4/tasks/321>
<https://www.illustrativemathematics.org/content-standards/5/NF/B/4/tasks/2078>
<https://www.illustrativemathematics.org/content-standards/5/NF/B/4/tasks/965>

Georgia Department of Education
Georgia Standards of Excellence Middle School Support
GSE Grade 6 • Connections/Support Materials for Remediation

<https://www.illustrativemathematics.org/content-standards/5/NF/B/4/tasks/2079>
<https://www.illustrativemathematics.org/content-standards/5/NF/B/6/tasks/1174>
<https://www.illustrativemathematics.org/content-standards/5/NF/B/6/tasks/295>
<https://www.illustrativemathematics.org/content-standards/5/NF/B/6/tasks/296>
<https://www.illustrativemathematics.org/content-standards/5/NF/B/6/tasks/297>
<https://www.illustrativemathematics.org/content-standards/5/NF/B/6/tasks/294>
<https://www.illustrativemathematics.org/content-standards/5/NF/B/7/tasks/12>
<https://www.illustrativemathematics.org/content-standards/5/NF/B/7/tasks/829>
<https://www.illustrativemathematics.org/content-standards/5/NF/A/tasks/1518>
<https://www.illustrativemathematics.org/content-standards/5/NF/A/2/tasks/1172>
<https://www.illustrativemathematics.org/content-standards/5/NF/A/2/tasks/2074>
<https://www.illustrativemathematics.org/content-standards/5/NF/B/4/tasks/2080>
<https://www.illustrativemathematics.org/content-standards/5/NF/B/6/tasks/2102>
<https://www.illustrativemathematics.org/content-standards/5/NF/B/7/tasks/1196>
<https://www.illustrativemathematics.org/content-standards/5/NF/B/7/tasks/957>
<https://www.illustrativemathematics.org/content-standards/5/NF/B/7/tasks/1120>
<https://www.illustrativemathematics.org/content-standards/5/NF/B/7/tasks/958>
<https://www.illustrativemathematics.org/content-standards/5/NF/B/7/tasks/932>

- **Understand Factor and Multiple Relationships**

<https://illuminations.nctm.org/Activity.aspx?id=3511>
<https://www.illustrativemathematics.org/content-standards/4/OA/B/tasks/959>
<https://www.illustrativemathematics.org/content-standards/4/OA/B/tasks/1484>
<https://www.illustrativemathematics.org/content-standards/4/OA/B/tasks/1493>
<https://www.illustrativemathematics.org/content-standards/4/OA/B/4/tasks/938>

- **Use and Represent Data**

<https://www.illustrativemathematics.org/content-standards/5/MD/B/2/tasks/1563>
<https://www.illustrativemathematics.org/content-standards/4/MD/B/4/tasks/1039>

Unit 2

- **Use Divisibility Rules**

<https://www.mathsisfun.com/divisibility-rules.html>
http://www.mathplayground.com/howto_divisibility.html
<https://www.khanacademy.org/math/pre-algebra/pre-algebra-factors-multiples/pre-algebra-divisibility-tests/v/divisibility-tests-for-2-3-4-5-6-9-10>

- **Use and Understand Relationships and Rules for Multiplication and Division of Whole Numbers as They Apply to Decimal Fractions**

Multiples: <https://illuminations.nctm.org/Lesson.aspx?id=3697> <https://gfletchy.com/dill-er-up/>

Decimals: <https://illuminations.nctm.org/Lesson.aspx?id=3655>

Multiplication: <https://illuminations.nctm.org/Lesson.aspx?id=3311>,
<https://illuminations.nctm.org/Lesson.aspx?id=3210>
<https://illuminations.nctm.org/Lesson.aspx?id=1703>

Multiplication/Division: <https://gfletchy.com/arraybow-of-colors/>
<https://gfletchy.com/krispy-kreme-me/>

Adding/Subtraction: <https://gfletchy.com/wheres-the-beef/>

Fractions: <https://gfletchy.com/do-the-dew/> <https://gfletchy.com/the-apple/>

Unit 3

- **Use Parentheses, Brackets, or Braces in Numerical Expressions and Evaluate Expressions with these Symbols**

<https://www.illustrativemathematics.org/content-standards/5/OA/A/tasks/1630>
<https://www.illustrativemathematics.org/content-standards/5/OA/A/tasks/1606>
<https://www.illustrativemathematics.org/content-standards/5/OA/A/1/tasks/969>
<https://www.illustrativemathematics.org/content-standards/5/OA/A/1/tasks/1596>
<https://www.illustrativemathematics.org/content-standards/5/OA/A/1/tasks/555>

- **Write and Interpret Numerical Expressions**

<https://www.illustrativemathematics.org/content-standards/5/OA/A/2/tasks/139>
<https://www.illustrativemathematics.org/content-standards/5/OA/A/2/tasks/1222>
<https://www.illustrativemathematics.org/content-standards/5/OA/A/2/tasks/590>
<https://www.illustrativemathematics.org/content-standards/5/OA/A/2/tasks/556>
<http://robertkaplinsky.com/work/enough-money/>

- **Generate Two Numerical Patterns using Two Given Rules**

<https://www.illustrativemathematics.org/content-standards/5/OA/B/3/tasks/1895>
<https://illuminations.nctm.org/Lesson.aspx?id=6561>

Intervention Tip: Patterns using different shapes (such as pattern blocks) can be helpful to students needing support since the differing shapes can help them focus on what is changing and staying the same.

For more visual patterns to try with your students, go to the source:
www.visualpatterns.org

Unit 4

The following additional resources may be useful:

- [Hands On Equations](#)
- [Pedal Power](#) – NCTM illuminations lesson on translating a graph to a story
- Interactive [grapher](#) from the National Library of Virtual Manipulatives
- [Algebra Balance Scales](#) from the National Library of Virtual Manipulatives

Allow students to explore interactive graphs, such as:

- http://www.colmanweb.co.uk/Assets/SWF/Skate_boarders.swf
- <http://www.absorblearning.com/media/attachment.action?quick=wl&att=2335>
- <http://www.explorelearning.com/index.cfm?method=cResource.dspView&ResourceID=260>

Unit 5

- **Evaluate Formulas for Finding Area, Surface Area, and Volume**

<https://www.illustrativemathematics.org/content-standards/5/MD/C/5/tasks/1971>
<https://www.illustrativemathematics.org/content-standards/5/MD/C/5/tasks/1655>
<https://www.illustrativemathematics.org/content-standards/5/MD/C/5/tasks/1308>

- **Find Area Measures in Square Units and Volume Measures in Cubic Units**

<https://www.illustrativemathematics.org/content-standards/5/MD/C/tasks/1031>

- **Identify Properties of Polygons, 2-D, and 3-D Shapes**

<https://www.illustrativemathematics.org/content-standards/5/G/B/3/tasks/1941>
<https://www.illustrativemathematics.org/content-standards/5/G/B/4/tasks/1943>
<https://www.illustrativemathematics.org/content-tandards/5/G/B/4/tasks/1505>

Intervention Notes: Students can explore the area of triangles using the following Illuminations web site: <http://illuminations.nctm.org/ActivityDetail.aspx?ID=108>. On this site, students are able to move all of the three vertices of the triangle. The program gives the length of the base and the height, as well as the area of the triangle. This information can be added to a table, allowing students to look for patterns. Students should recognize that no matter how the shape of the triangle changes, the height of the triangle is always perpendicular to the base.

- **Find area of squares, rectangles, and triangles, and finding the perimeter of squares and rectangles.**

<https://www.illustrativemathematics.org/content-standards/tasks/1836>
<https://www.illustrativemathematics.org/content-standards/tasks/1515>
<https://www.illustrativemathematics.org/content-standards/tasks/876>
<https://www.illustrativemathematics.org/content-standards/tasks/516>
<https://www.illustrativemathematics.org/content-standards/tasks/510>

Unit 6

- **Analyze Patterns and Identify Relationships**

<https://www.illustrativemathematics.org/content-standards/4/OA/C/5/tasks/487>
<https://www.illustrativemathematics.org/content-standards/4/OA/C/5/tasks/1481>
<https://www.illustrativemathematics.org/content-standards/5/OA/B/3/tasks/1895>

STANDARDS FOR MATHEMATICAL CONTENT

The content standards for Foundations of Algebra are an amalgamation of mathematical standards addressed in grades 3 through high school.

After each Foundations of Algebra standard there is a list of reference standards. These reference standards refer to the standards used to form those for Foundations of Algebra.

Students will compare different representations of numbers (i.e., fractions, decimals, radicals, etc.) and perform basic operations using these different representations.

MFANSQ1. Students will analyze number relationships.

- Solve multi-step real world problems, analyzing the relationships between all four operations. For example, understand division as an unknown-factor problem in order to solve problems. Knowing that $50 \times 40 = 2000$ helps students determine how many boxes of cupcakes they will need in order to ship 2000 cupcakes in boxes that hold 40 cupcakes each. (MGSE3.OA.6, MGSE4.OA.3)
- Understand a fraction a/b as a multiple of $1/b$. (MGSE4.NF.4)
- Explain patterns in the placement of decimal points when multiplying or dividing by powers of ten. (MGSE5.NBT.2)
- Compare fractions and decimals to the thousandths place. For fractions, use strategies other than cross multiplication. For example, locating the fractions on a number line or using benchmark fractions to reason about relative size. For decimals, use place value. (MGSE4.NF.2; MGSE5.NBT.3,4)

MFANSQ2. Students will conceptualize positive and negative numbers (including decimals and fractions).

- Explain the meaning of zero. (MGSE6.NS.5)
- Represent numbers on a number line. (MGSE6.NS.5,6)
- Explain meanings of real numbers in a real world context. (MGSE6.NS.5)

MFANSQ4. Students will apply and extend previous understanding of addition, subtraction, multiplication, and division.

- a. Find sums, differences, products, and quotients of multi-digit decimals using strategies based on place value, the properties of operations, and/or relationships between operations. (MGSE5.NBT.7; MGSE6.NS.3)
- b. Find sums, differences, products, and quotients of all forms of rational numbers, stressing the conceptual understanding of these operations. (MGSE7.NS.1,2) *Restrict to operations with natural (counting) numbers and whole numbers for use in 6th Grade.*
- c. Interpret and solve contextual problems involving division of fractions by fractions. For example, how many $\frac{3}{4}$ -cup servings are in $\frac{2}{3}$ of a cup of yogurt? (MGSE6.NS.1)
- d. Illustrate and explain calculations using models and line diagrams. (MGSE7.NS.1,2)

Students will extend arithmetic operations to algebraic modeling.

MFAAA1. Students will generate and interpret equivalent numeric and algebraic expressions.

- a. Apply properties of operations emphasizing when the commutative property applies. (MGSE7.EE.1)
- b. Use area models to represent the distributive property and develop understandings of addition and multiplication (all positive rational numbers should be included in the models). (MGSE3.MD.7)
- c. Model numerical expressions (arrays) leading to the modeling of algebraic expressions. (MGSE7.EE.1,2 , MGSE9-12.A.SSE.1,3)
- d. Add, subtract, and multiply algebraic expressions. (MGSE6.EE.3,4, MGSE7.EE.1, MGSE9-12.A.SSE.3)
- e. Generate equivalent expressions using properties of operations and understand various representations within context. *For example, distinguish multiplicative comparison from additive comparison. Students should be able to explain the difference between “3 more” and “3 times”.* (MGSE4.OA.2; MGSE6.EE.3, MGSE7.EE.1,2 ,MGSE9-12.A.SSE.3)
- f. Evaluate formulas at specific values for variables. *For example, use formulas such as $A = l \times w$ and find the area given the values for the length and width.* (MGSE6.EE.2)

Students will use ratios to solve real-world and mathematical problems.

MFAPR1. Students will explain equivalent ratios by using a variety of models. For example, tables of values, tape diagrams, bar models, double number line diagrams, and equations. (MGSE6.RP.3)

MFAPR2. Students will recognize and represent proportional relationships between quantities.

- a. Relate proportionality to fraction equivalence and division. *For example, $\frac{3}{6}$ is equal to $\frac{4}{8}$ because both yield a quotient of $\frac{1}{2}$ and, in both cases, the denominator is double the value of the numerator.* (MGSE4.NF.1)
- b. Understand real-world rate/ratio/percent problems by finding the whole given a part and find a part given the whole. (MGSE6.RP.1,2,3; MGSE7.RP.1,2)
- c. Use proportional relationships to solve multistep ratio and percent problems. (MGSE7.RP.2,3)

Students will solve, interpret, and create linear models using equations and inequalities.

MFAEI1. Students will create and solve equations and inequalities in one variable.

- a. Use variables to represent an unknown number in a specified set (conceptual understanding of a variable). (MGSE6.EE.2, 5, 6)
- e. Use variables to solve real-world and mathematical problems. (MGSE6.EE.7, MGSE7.EE.4)

MFAEI2. Students will use units as a way to understand problems and guide the solutions of multi-step problems.

- b. Choose and interpret graphs and data displays, including scale and comparisons of data. (MGSE3.MD.3, MGSE9-12.N.Q.1)
- c. Graph points in all four quadrants of the coordinate plane. (MGSE6.NS.8)

ELEMENTARY REFERENCE STANDARDS

These reference standards refer to the standards used to form the standards for the Foundations of Algebra course. Below, you will find the elementary reference standards with instructional strategies and common misconceptions.

MGSE.3.OA.6. Understand division as an unknown-factor problem. *For example, find $32 \div 8$ by finding the number that makes 32 when multiplied by 8.*

Since multiplication and division are inverse operations, students are expected to solve problems and explain their processes of solving division problems that can also be represented as unknown factor multiplication problems.

Example: A student knows that $2 \times 9 = 18$. How can they use that fact to determine the answer to the following question: 18 people are divided into pairs in a P.E. class? How many pairs are there? Write a division equation and explain your reasoning.

Multiplication and division are inverse operations and that understanding can be used to find the unknown. Fact family triangles demonstrate the inverse operations of multiplication and division by showing the two factors and how those factors relate to the product and/or quotient. Examples:

$$3 \times 5 = 15 \qquad 5 \times 3 = 15$$

$$15 \div 3 = 5 \qquad 15 \div 5 = 3$$

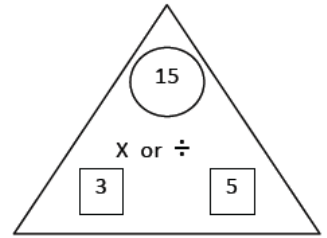

MGSE.3.MD.7 Relate area to the operations of multiplication and addition.
a. Find the area of a rectangle with whole-number side lengths by tiling it, and show that the area is the same as would be found by multiplying the side lengths.

Students should tile rectangles, then multiply their side lengths to show it is the same.

To find the area, one could count the squares or multiply
 $3 \times 4 = 12$.

1	2	3	4
5	6	6	8
9	10	11	12

b. Multiply side lengths to find areas of rectangles with whole-number side lengths in the context of solving real world and mathematical problems, and represent whole-number products as rectangular areas in mathematical reasoning.

Students should solve real world and mathematical problems

Example:

Drew wants to tile the bathroom floor using 1 foot tiles. How many square foot tiles will he need?

6 feet



8 feet

The area of the rectangle is 48 square feet, and since each tile is 1 square foot, 48 tiles will be needed.

c. Use tiling to show in a concrete case that the area of a rectangle with whole-number side lengths a and $b + c$ is the sum of $a \times b$ and $a \times c$. Use area models to represent the distributive property in mathematical reasoning.

This standard extends students' work with the distributive property. For example, in the picture below the area of a 7×6 figure can be determined by finding the area of a 5×6 and 2×6 and adding the two sums.

So, $7 \times 6 = (5 + 2) \times 6 = 5 \times 6 + 2 \times 6 = 30 + 12 = 42$

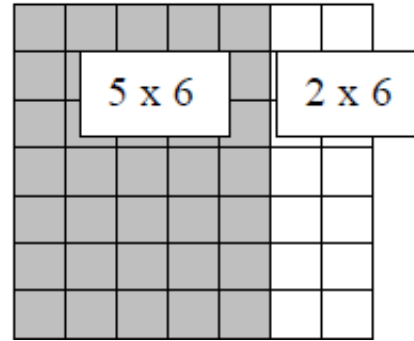

Example:

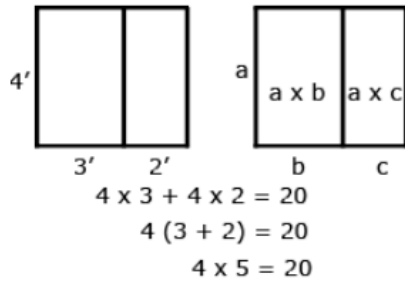

Recognize area as additive. Find areas of rectilinear figures by decomposing them into non-overlapping rectangles and adding the areas of the non-overlapping parts, applying this technique to solve real world problems.

This standard uses the word rectilinear. A rectilinear figure is a polygon that has all right angles.

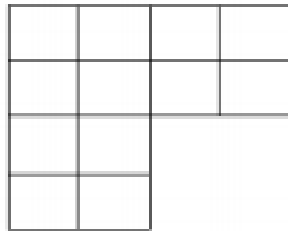

How could this figure be decomposed to help find the area?

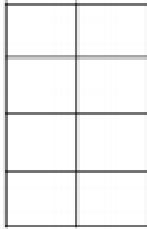
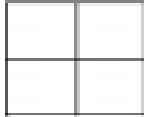
 <p style="text-align: center;">This portion of the decomposed figure is a 4×2.</p>	 <p style="text-align: center;">This portion of the decomposed figure is 2×2.</p>
--	--

$4 \times 2 = 8$ and $2 \times 2 = 4$
 So $8 + 4 = 12$

Therefore the total area of this figure is 12 square units

Example 1:

A storage shed is pictured below. What is the total area? How could the figure be decomposed to help find the area?

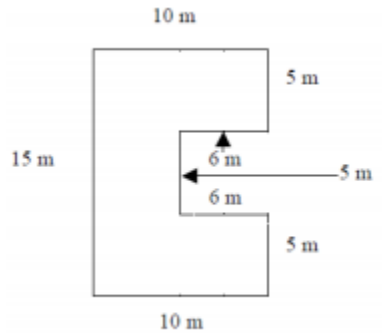

The area can be found by using 3 rectangles:

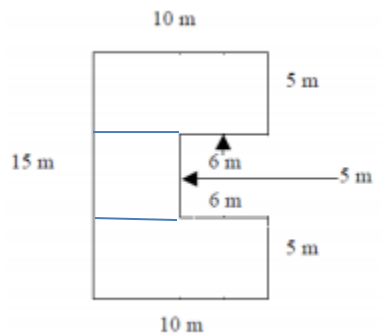

The top and bottom of the figure will be $10\text{ m} \times 5\text{ m}$ for $50\text{ m}^2 \times 2 = 100\text{ m}^2$
 The center rectangle will be a square with dimensions $5\text{ m} \times (15 - 5 - 5)\text{ m} = 5\text{ m} \times 5\text{ m}$ or 25 m^2
 So, the area of the storage shed is 125 square meters.

Example 2:

As seen above, students can decompose a rectilinear figure into different rectangles. They find the area of the figure by adding the areas of each of the rectangles together.

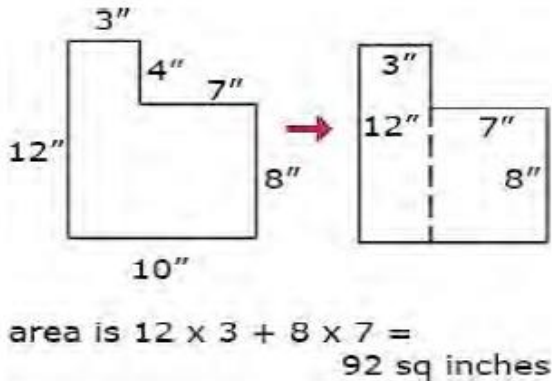

Common Misconceptions

Students may confuse perimeter and area when they measure the sides of a rectangle and then multiply. They think the attribute they find is length, which is perimeter. Pose problems situations that require students to explain whether they are to find the perimeter or area.

MGSE.4.OA.2. Multiply or divide to solve word problems involving multiplicative comparison. Use drawings and equations with a symbol or letter for the unknown number to represent the problem, distinguishing multiplicative comparison from additive comparison.

This standard calls for students to translate comparative situations into equations with an unknown and solve. Students need many opportunities to solve contextual problems.

Examples:

Unknown Product: A blue scarf costs \$3. A red scarf costs 6 times as much. How much does the red scarf cost? ($3 \times 6 = p$)

Group Size Unknown: A book costs \$18. That is 3 times more than a DVD. How much does a DVD cost? ($18 \div p = 3$ or $3 \times p = 18$)

Number of Groups Unknown: A red scarf costs \$18. A blue scarf costs \$6. How many times as much does the red scarf cost compared to the blue scarf? ($18 \div 6 = p$ or $6 \times p = 18$)

When distinguishing multiplicative comparison from additive comparison, students should note the following:

- Additive comparisons focus on the difference between two quantities. For example, Deb has 3 apples and Karen has 5 apples. How many more apples does Karen have? A simple way to remember this is, “How many more?”
- Multiplicative comparisons focus on comparing two quantities by showing that one quantity is a specified number of times larger or smaller than the other. For example, Deb ran 3 miles. Karen ran 5 times as many miles as Deb. How many miles did Karen run? A simple way to remember this is “How many times as much?” or “How many times as many?”

MGSE.4.OA.3. Solve multistep word problems with whole numbers and having whole-number answers using the four operations, including problems in which remainders must be interpreted. Represent these problems using equations with a symbol or letter standing for the unknown quantity. Assess the reasonableness of answers using mental computation and estimation strategies including rounding

The focus in this standard is to have students use and discuss various strategies. The reference is to estimation strategies, including using compatible numbers (numbers that sum to 10 or 100) or rounding. Problems should be structured so that all acceptable estimation strategies will arrive at a reasonable answer. Students need many opportunities solving multistep story problems using all four operations.

Example 1:

On a vacation, your family travels 267 miles on the first day, 194 miles on the second day and 34 miles on the third day. How many miles did they travel total?

Some typical estimation strategies for this problem are shown below:

Student 1:

I first thought about 267 and 34. I noticed that their sum is about 300. Then I knew that 194 is close to 200. When I put 300 and 200 together, I get 500.

Student 2:

I first thought about 194. It is really close to 200. I also have 2 hundreds in 267. That gives me a total of 4 hundreds. Then I have 67 in 267 and the 34. When I put 67 and 34 together that is really close to 100. When I add that hundred to the 4 hundreds that I already had, I end up with 500.

Student 3:

I rounded 267 to 300. I rounded 194 to 200. I rounded 34 to 30. When I added 300, 200, and 30, I know my answer will be about 530.

The assessment of estimation strategies should have a reasonable answer (500 or 530), or a range (between 500 and 550). Problems will be structured so that all acceptable estimation strategies will arrive at a reasonable answer.

Example 2:

Your class is collecting bottled water for a service project. The goal is to collect 300 bottles of water. On the first day, Max brings in 3 containers with 6 bottles in each container. Sarah wheels in 6 containers with 6 bottles in each container. About how many bottles of water still need to be collected?

Student 1:

First I multiplied 3 and 6 which equals 18. Then I multiplied 6 and 6 which is 36. I know 18 plus 36 is about 50. I'm trying to get to 300. 50 plus another 50 is 100. Then I need 2 more hundreds. So we still need 250 bottles.

Student 2:

First I multiplied 3 and 6 which equals 18. Then I multiplied 6 and 6 which is 36. I know 18 is about 20 and 36 is about 40. $40 + 20 = 60$. $300 - 60 = 240$, so we need about 240 more bottles.

This standard also references interpreting remainders. Remainders should be put into context for interpretation. Ways to address remainders:

- Remained as a left over
- Partitioned into fractions or decimals
- Discarded leaving only the whole number answer
- Increased the whole number answer up one
- Rounded to the nearest whole number for an approximate result

Example 1:

Write different word problems involving $44 \div 6 = ?$ where the answers are best represented as:

- Problem A: 7
- Problem B: $7 \text{ r } 2$
- Problem C: 8
- Problem D: 7 or 8
- Problem E: $7 \frac{2}{6}$

Possible solutions:

Problem A: 7.

Mary had 44 pencils. Six pencils fit into each of her pencil pouches. How many pouches did she fill? $44 \div 6 = p$; $p = 7 \text{ r } 2$. *Mary can fill 7 pouches completely.*

Problem B: $7 \text{ r } 2$.

Mary had 44 pencils. Six pencils fit into each of her pencil pouches. How many pouches could she fill and how many pencils would she have left? $44 \div 6 = p$; $p = 7 \text{ r } 2$; *Mary can fill 7 pouches and have 2 left over.*

Problem C: 8.

Mary had 44 pencils. Six pencils fit into each of her pencil pouches. What would the fewest number of pouches she would need in order to hold all of her pencils? $44 \div 6 = p$; $p = 7 \text{ r } 2$; *Mary needs 8 pouches to hold all of the pencils.*

Problem D: 7 or 8.

Mary had 44 pencils. She divided them equally among her friends before giving one of the leftovers to each of her friends. How many pencils could her friends have received? $44 \div 6 = p$; $p = 7 \text{ r } 2$; *some of her friends received 7 pencils. Two friends received 8 pencils.*

Problem E: $7 \frac{2}{6}$.

Mary had 44 pencils and put six pencils in each pouch. What fraction represents the number of pouches that Mary filled? $44 \div 6 = p$; $p = 7 \frac{2}{6}$

Example 2:

There are 128 students going on a field trip. If each bus held 30 students, how many buses are needed? ($128 \div 30 = b$; $b = 4 R 8$). *They will need 5 buses because 4 buses would not hold all of the students).*

Students need to realize in problems, such as the examples above, that an extra bus is needed for the 8 students that are left over. Estimation skills include identifying when estimation is appropriate, determining the level of accuracy needed, selecting the appropriate method of estimation, and verifying solutions or determining the reasonableness of situations using various estimation strategies. Estimation strategies include, but are not limited to the following:

- **Front-end estimation with adjusting** (Using the highest place value and estimating from the front end, making adjustments to the estimate by taking into account the remaining amounts)
- **Clustering around an average** (When the values are close together, an average value is selected and multiplied by the number of values to determine an estimate.)
- **Rounding and adjusting** (Students round down or round up and then adjust their estimate depending on how much the rounding affected the original values.)
- **Using friendly or compatible numbers such as factors** (Students seek to fit numbers together; e.g., rounding to factors and grouping numbers together that have round sums like 100 or 1000.)
- **Using benchmark numbers that are easy to compute** (Students select close whole numbers for fractions or decimals to determine an estimate.)
-

MGSE.4.NF.1 Explain why two or more fractions are equivalent. $\frac{a}{b} = \frac{n \times a}{n \times b}$. $\frac{1}{4} = \frac{3 \times 1}{3 \times 4}$ by using visual fraction models. Focus attention on how the number and size of the parts differ even though the fractions themselves are the same size. Use this principle to recognize and generate equivalent fractions.

This standard refers to visual fraction models. This includes area models or number lines. This standard extends the work in third grade by using additional denominators (5, 10, 12, and 100).

The standard addresses equivalent fractions by examining the idea that equivalent fractions can be created by multiplying both the numerator and denominator by the same number or by dividing a shaded region into various parts.

Example:

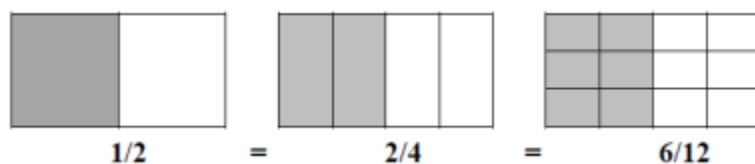

Technology Connection: <http://illuminations.nctm.org/activitydetail.aspx?id=80>

MGSE.4.NF.2. Compare two fractions with different numerators and different denominators, e.g., by using visual fraction models, by creating common denominators or numerators, or by comparing to a benchmark fraction such as $\frac{1}{2}$. Recognize that comparisons are valid only when the two fractions refer to the same whole. Record the results of comparisons with symbols $>$, $=$, or $<$, and justify the conclusions.

This standard asks students to compare fractions by creating visual fraction models or finding common denominators or numerators. **Students' experiences should focus on visual fraction models rather than algorithms.** When tested, models may or may not be included. Students should learn to draw fraction models to help them compare. Students must also recognize that they must consider the size of the whole when comparing fractions (i.e., $\frac{1}{2}$ and $\frac{1}{8}$ of two medium pizzas is very different from $\frac{1}{2}$ of one medium and $\frac{1}{8}$ of one large).

Example 1:

Use pattern blocks.

- If a red trapezoid is one whole, which block shows $\frac{1}{3}$?
- If the blue rhombus is $\frac{1}{3}$, which block shows one whole?
- If the red trapezoid is one whole, which block shows $\frac{2}{3}$?

Example 2:

Mary used a 12×12 grid to represent 1 and Janet used a 10×10 grid to represent 1. Each girl shaded grid squares to show $\frac{1}{4}$. How many grid squares did Mary shade? How many grid squares did Janet shade? Why did they need to shade different numbers of grid squares?

Possible solution: Mary shaded 36 grid squares; Janet shaded 25 grid squares. The total number of little squares is different in the two grids, so $\frac{1}{4}$ of each total number is different.

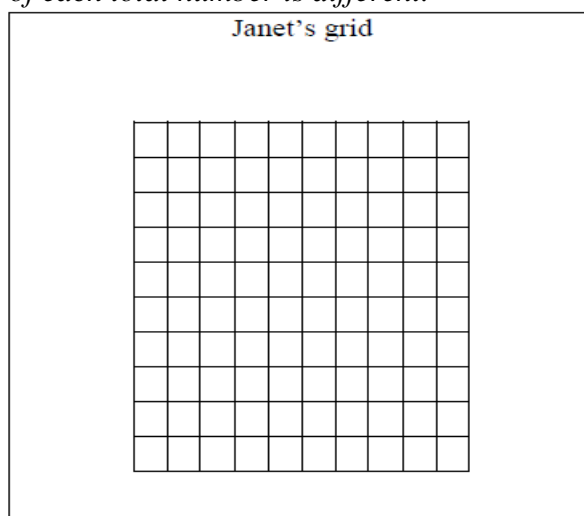
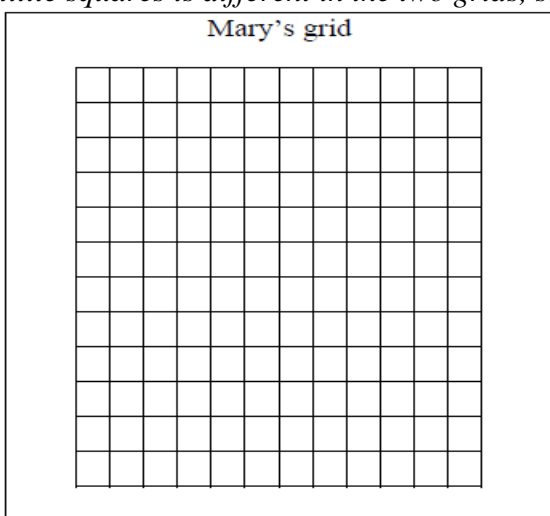

Example 3:

There are two cakes on the counter that are the same size. The first cake has $\frac{1}{2}$ left. The second cake has $\frac{5}{12}$ left. Which cake has more left?

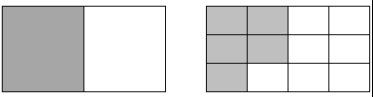
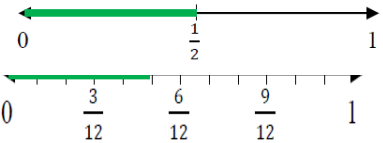
<p>Student 1: Area Model</p> <p>The first cake has more left over. The second cake has $\frac{5}{12}$ left which is smaller than $\frac{1}{2}$.</p>	
<p>Student 2: Number Line Model</p> <p>The first cake has more left over: $\frac{1}{2}$ is bigger than $\frac{5}{12}$</p>	
<p>Student 3: Verbal Explanation</p> <p>I know that $\frac{6}{12}$ equals $\frac{1}{2}$, and $\frac{5}{12}$ is less than $\frac{1}{2}$. Therefore, the second cake has less left over than the first cake. The first cake has more left over.</p>	

Example 4:

When using the benchmark of $\frac{1}{2}$ to compare $\frac{4}{6}$ and $\frac{5}{8}$, you could use diagrams such as these:

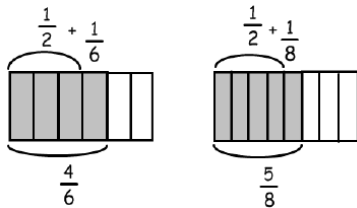

$\frac{4}{6}$ is $\frac{1}{6}$ larger than $\frac{1}{2}$, while $\frac{5}{8}$ is $\frac{1}{8}$ larger than $\frac{1}{2}$. Since $\frac{1}{6}$ is greater than $\frac{1}{8}$, $\frac{4}{6}$ is the greater fraction.

Common Misconceptions

Students think that when generating equivalent fractions they need to multiply or divide either the numerator or denominator by the same number rather than the numerator **and** denominator. For example, when making equivalent fractions for $\frac{5}{6}$, a student may multiply just the numerator by 2 resulting in $\frac{10}{6}$ instead of correctly multiplying by $\frac{2}{2}$ with the result $\frac{10}{12}$.

This misconception comes about because students do not understand that they **need to use a fraction in the form of one**, such as $\frac{2}{2}$ to generate an equivalent fraction. Reviewing the identity property with students reemphasizing what happens when we multiply by 1 is an essential component of instruction when addressing this misconception. Conversation centered around “what one (in disguise) could we use to create an equivalent fraction?”

MGSE.5.NBT.2 Explain patterns in the number of zeros of the product when multiplying a number by powers of 10, and explain patterns in the placement of the decimal point when a decimal is multiplied or divided by a power of 10. Use whole-number exponents to denote powers of 10.

This standard includes multiplying by multiples of 10 and powers of 10, including 10^2 which is $10 \times 10 = 100$, and 10^3 which is $10 \times 10 \times 10 = 1,000$. Students should have experiences working with connecting the pattern of the number of zeros in the product when you multiply by powers of 10.

Example 1: $2.5 \times 10^3 = 2.5 \times (10 \times 10 \times 10) = 2.5 \times 1,000 = 2,500$

Students should reason that the exponent above the 10 indicates how many places the decimal point is moving (not just that the decimal point is moving but that you are multiplying or making the number 10 times greater three times) when you multiply by a power of 10. Since we are multiplying by a power of 10 the decimal point moves to the right.

Example 2: $350 \div 10^3$

$350 \div 10^3 = 350 \div 1,000$ (This extra representation should be added so that the decimal is just not “moving”) $= 0.350 = 0.35$

Example 3: $^{350}/_{10}$

$^{350}/_{10} = (350 \times \frac{1}{10}) = ^{35}/_1 = 35$ The second step emphasizes that the “0” just does not disappear. This example shows that when we divide by powers of 10, the exponent above the 10 indicates how many places the decimal point is moving (how many times we are dividing by 10, the number becomes ten times smaller). Since we are dividing by powers of 10, the decimal point moves to the left. Students need to be provided with opportunities to explore this concept and come to this understanding; this **should not just be taught procedurally**.

MGSE.5.NBT.3. Read, write, and compare decimals to thousandths.

- a. **Read and write decimals to thousandths using base-ten numerals, number names, and expanded form, e.g., $347.392 = 3 \times 100 + 4 \times 10 + 7 \times 1 + 3 \times (1/10) + 9 \times (1/100) + 2 \times (1/1000)$.**
- b. **Compare two decimals to thousandths based on meanings of the digits in each place, using $>$, $=$, and $<$ symbols to record the results of comparisons.**

This standard references the expanded form of decimals with fractions included. Students should build on their work from 4th grade, where they worked with both decimals and fractions interchangeably. Expanded form is included to build upon work in **MGSE.5.NBT.2** and to deepen students’ understanding of place value.

Students will also build on the understanding they developed in fourth grade to read, write, and compare decimals to thousandths. They will connect to their prior experiences of using decimal

notation for fractions in the addition of fractions with denominators of 10 and 100. When dealing with tenths and hundredths, conversation about money (cents) can help students make connections to using decimals in real world contexts.

Students will benefit by using concrete models and number lines to read, write, and compare decimals to the thousandths. Models may include base ten blocks, place value charts, grids, pictures, drawings, manipulatives, website virtual manipulatives etc. They will need to read decimals using fractional language and to write decimals in fractional form, as well as in expanded notation. This investigation leads to understanding equivalence of decimals ($0.8 = 0.80 = 0.800$).

Example:

Some equivalent forms of 0.72 are:

$\frac{72}{100}$	$\frac{70}{100} + \frac{2}{100}$
$\frac{7}{10} + \frac{2}{100}$	0.720
$7 \times (\frac{1}{10}) + 2 \times (\frac{1}{100})$	$7 \times (\frac{1}{10}) + 2 \times (\frac{1}{100}) + 0 \times (\frac{1}{1000})$
0.70 + 0.02	$\frac{720}{1000}$

Students need to conceptually understand the size of decimal numbers and to relate them to common benchmarks such as 0, 0.5 (0.50 and 0.500), and 1. Comparing tenths to tenths, hundredths to hundredths, and thousandths to thousandths is simplified if students use their understanding of fractions to compare decimals.

Example:

Comparing 0.25 and 0.17, a student might think, “25 hundredths is more than 17 hundredths”. They may also think that it is 8 hundredths more. They may write this comparison as $0.25 > 0.17$ and recognize that $0.17 < 0.25$ is another way to express this comparison. Additionally, connecting to money, “\$0.25 is more than \$0.17” or “\$0.17 is less than \$0.25”

Comparing 0.207 to 0.26, a student might think, “Both numbers have 2 tenths, so I need to compare the hundredths. The second number has 6 hundredths and the first number has no hundredths so the second number must be larger. Another student might think while writing fractions, “I know that 0.207 is 207 thousandths (and may write $\frac{207}{1000}$). 0.26 is 26 hundredths (and may write $\frac{26}{100}$) but I can also think of it as 260 thousandths ($\frac{260}{1000}$). So, 260 thousandths is more than 207 thousandths.

MGSE.5.NBT.4. Use place value understanding to round decimals up to the hundredths place

This standard refers to rounding. Students should go beyond simply applying an algorithm or procedure for rounding. The expectation is that students have a deep understanding of place value and number sense and can explain and reason about the answers they get when they round. Students should have numerous experiences using a number line to support their work with rounding.

Example:

Round 14.235 to the nearest tenth.

Students **must** recognize that the possible answer must be in tenths thus, it is either 14.2 or 14.3. They then identify that 14.235 is closer to 14.2 (14.20) than to 14.3 (14.30).

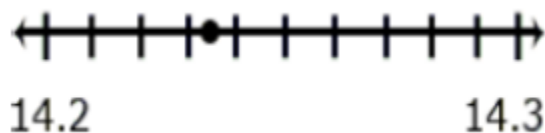

Students should use benchmark numbers to support this work. Benchmarks are convenient numbers for comparing and rounding numbers. 0, 0.5, 1, 1.5 are examples of benchmark numbers.

Example:

Which benchmark number is the best estimate of the shaded amount in the model below? Explain your thinking.

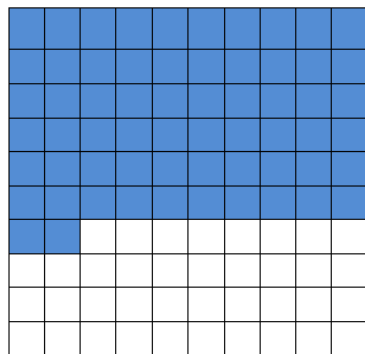

In this case 0.62 would be the number to be rounded to the nearest tenth. By seeing that the “extra blocks” are closest to $\frac{60}{100}$, the colored blocks show that 0.6 would be the closest value.

Common Misconceptions

A misconception that is directly related to the comparison of whole numbers and the comparison of decimals is the idea that the more digits a number contains means the greater the value of the number. With whole numbers, a 5-digit number is always greater than a 1-, 2-, 3-, or 4-digit number. However, with decimals, a number with one decimal place may be greater than a number with two or three decimal places. For example, 0.5 is greater than 0.12, 0.009 or 0.499. One method for comparing decimals is to rewrite all numbers so that they have the same number of digits to the right of the decimals point, such as 0.500, 0.120, 0.009 and 0.499. A second method is to use a place-value chart to place the numerals for comparison. A third would be to think of the

amount as money and have students' first compare the "cents" decimal positions (tenths and hundredths) to determine how much "change" they are looking at for each example.

MGSE.5.NBT.7 Add, subtract, multiply, and divide decimals to hundredths, using concrete models or drawings and strategies based on place value, properties of operations, and/or the relationship between addition and subtraction; relate the strategy to a written method and explain the reasoning used.

This standard also builds on work begun in 4th grade when students were introduced to decimals and asked to compare them. In 5th grade, students begin adding, subtracting, multiplying and dividing decimals. This work should focus on concrete models and pictorial representations, rather than relying solely on the algorithm. The use of symbolic notations involves having students record the answers to computations ($2.25 \times 3 = 6.75$), but this work should not be done without models or pictures. This standard requires that students explain their reasoning and how they use models, pictures, and strategies. Students are expected to extend their understanding of whole number models and strategies to decimal values. Before students are asked to give exact answers, they should estimate answers based on their understanding of operations and the value of the numbers.

Examples:

5.4 – 0.8

A student might estimate the answer to be a little more than 4.4 because a number less than 1 is being subtracted.

6 × 2.4

A student might estimate an answer between 12 and 18 since 6×2 is 12 and 6×3 is 18. Another student might give an estimate of a little less than 15 because s/he figures the answer to be very close, but smaller than $6 \times 2\frac{1}{2}$ and think of $2\frac{1}{2}$ groups of 6 as 12 (2 groups of 6) + $3(\frac{1}{2}$ of a group of 6).

When adding or subtracting decimals, students should be able to explain that tenths are added or subtracted from tenths and hundredths are added or subtracted from hundredths. So, students will need to communicate that when adding or subtracting in a vertical format (numbers beneath each other), it is important that digits with the same place value are written in the same column. This understanding can be reinforced by linking the decimal addition and subtraction process to addition and subtraction of fractions. Adding and subtracting fractions with like denominators of 10 and 100 is a standard in fourth grade.

Common Misconceptions

Students might compute the sum or difference of decimals by lining up the right-hand digits as they would whole number. For example, in computing the sum of $15.34 + 12.9$, students will write the problem in this manner:

$$\begin{array}{r} 15.34 \\ + 12.9 \\ \hline 16.63 \end{array}$$

To help students add and subtract decimals correctly, have them first estimate the sum or difference. Providing students with a decimal-place value chart will enable them to place the digits in the proper place.

Example 1: $4 - 0.3$

3 tenths subtracted from 4 wholes. One of the wholes must be divided into tenths.



The solution is $3 + \frac{7}{10}$ or 3.7.

Example 2:

A recipe for a cake requires 1.25 cups of milk, 0.40 cups of oil, and 0.75 cups of water. How much liquid is in the mixing bowl?

Student 1: $1.25 + 0.40 + 0.75$

First, I broke the numbers apart. I broke 1.25 into $1.00 + 0.20 + 0.05$. I left 0.40 like it was. I broke 0.75 into $0.70 + 0.05$.

I combined my two 0.05's to get 0.10. I combined 0.40 and 0.20 to get 0.60. I added the 1 whole from 1.25. I ended up with 1 whole, 6 tenths, 7 more tenths, and another 1 tenths, so the total is 2.4.

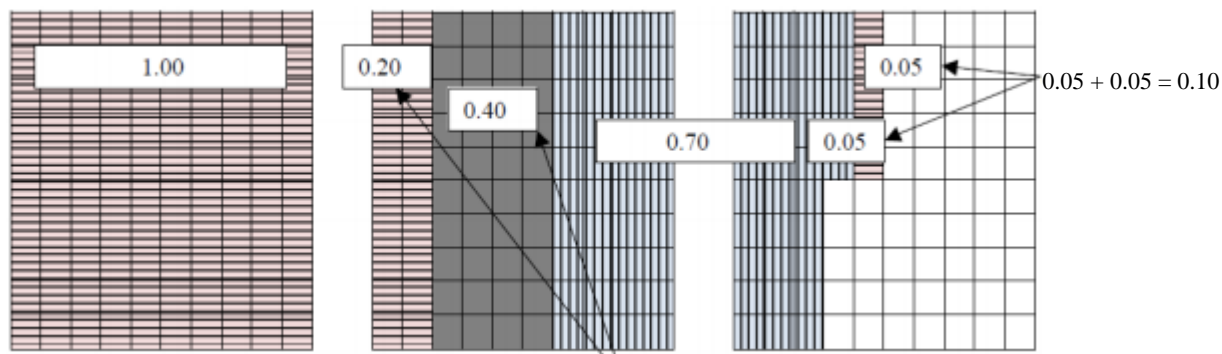

Student 2:

I saw that the 0.25 in the 1.25 cups of milk and the 0.75 cups of water would combine to equal 1 whole cup. That plus the 1 whole in the 1.25 cups of milk gives me 2 whole cups. Then I added the 2 wholes and the 0.40 cups of oil to get 2.40 cups.

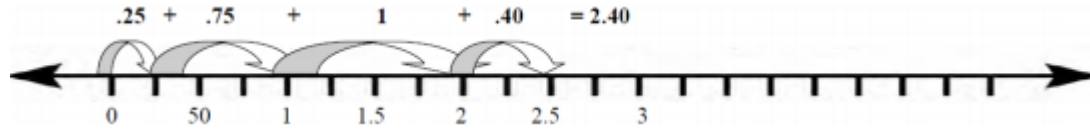

Example of Multiplication 1

A gumball costs \$0.22. How much do 5 gumballs cost? Estimate the total, and then calculate. Was your estimate close?

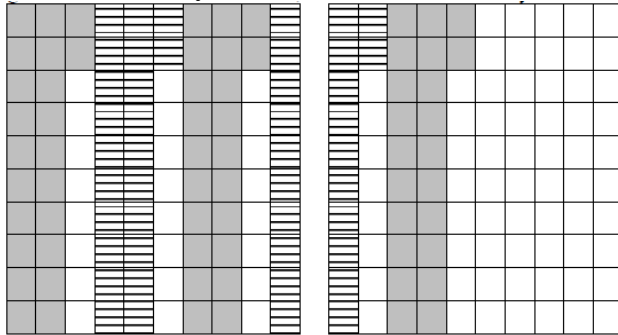

I estimate that the total cost will be a little more than a dollar. I know that 5 20's equal 100 and we have 5 22's. I have 10 whole columns shaded and 10 individual boxes shaded. The 10 columns equal 1 whole. The 10 individual boxes equal 10 hundredths or 1 tenth. My answer is \$1.10.

My estimate was a little more than a dollar, and my answer was \$1.10. I was really close.

Multiplication Example 2:

An area model can be useful for illustrating products.

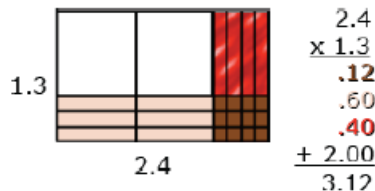

Students should be able to describe the partial products displayed by the area model.

For example, “ $\frac{3}{10}$ times $\frac{4}{10}$ is $\frac{12}{100}$.

$\frac{3}{10}$ times 2 is $\frac{6}{10}$ or $\frac{60}{100}$.

1 group of $\frac{4}{10}$ is $\frac{4}{10}$ or $\frac{40}{100}$.

1 group of 2 is 2.”

Division Example 1: Joe has 1.6 meters of rope. He has to cut pieces of rope that are 0.2 meters long. How many can he cut?

Finding the number of groups

Students could draw a segment to represent 1.6 meters. In doing so, s/he would count in tenths to identify the 6 tenths, and be able identify the number of 2 tenths within the 6 tenths. The student can then extend the idea of counting by tenths to divide the one meter into tenths and determine that there are 5 more groups of 2 tenths.

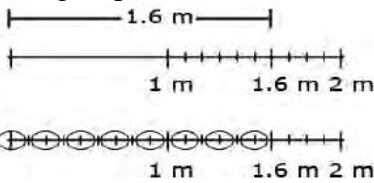

Students might count groups of 2 tenths without the use of models or diagrams. Knowing that 1 can be thought of as $\frac{10}{10}$, a student might think of 1.6 as 16 tenths. Counting 2 tenths, 4 tenths, 6 tenths, up to 16 tenths, a student can count 8 groups of 2 tenths. Use their understanding of multiplication and think, “8 groups of 2 is 16, so 8 groups of $\frac{2}{10}$ is $\frac{16}{10}$ or $1\frac{6}{10}$.”

Division Example 2: $2.4 \div 4$

Finding the number in each group or share:

Students should be encouraged to apply a fair sharing model separating decimal values into equal parts such as $2.4 \div 4 = 0.6$.



Division Example 3:

A relay race lasts 4.65 miles. The relay team has 3 runners. If each runner goes the same distance, how far does each team member run? Make an estimate, find your actual answer, and then compare them. (*Solution below.*)

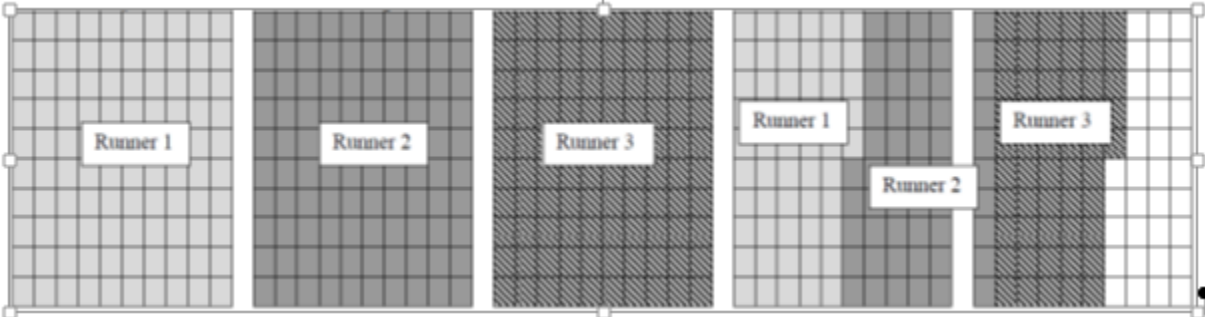

Each runner runs between 1 and 2 miles. If each runner went 2 miles, that would be a total of 6 miles (too high). If each runner ran 1 mile, that would be 3 miles, (too low). I used the 5 grids to represent the 4.65 miles. I am going to use all of the first 4 grids and 65 of the squares in the 5th grid. I have to divide the 4 whole grids and the 65 squares into 3 equal groups. I labeled each of the first 3 grids for each runner, so I know that each team member ran at least 1 mile. I have 1 whole grid and 65 squares to divide up. Each column represents one-tenth. If I give 5 columns to each runner, that means that each runner has run 1 whole mile and 5 tenths of a mile. Now, I have 15 squares left to divide up. Each runner gets 5 of those squares. So each runner ran 1 mile, 5 tenths and 5 hundredths of a mile. I can write that as 1.55 miles. My estimate was pretty close.

STANDARDS FOR MATHEMATICAL PRACTICE

The Standards for Mathematical Practice describe varieties of expertise that educators at all levels should seek to develop in their students. These practices rest on important “processes and proficiencies” with longstanding importance in education. The first of these are the National Council of Teachers of Mathematics (NCTM) process standards of problem solving, reasoning and proof, communication, representation, and connections. (*Principles and Standards for School Mathematics*. NCTM: 2000.) The second are the strands of mathematical proficiency specified in the National Research Council’s report *Adding It Up*: adaptive reasoning, strategic competence, conceptual understanding (comprehension of mathematical concepts, operations and relations), procedural fluency (skill in carrying out procedures flexibly, accurately, efficiently, and appropriately), and productive disposition (habitual inclination to see as sensible, useful, and worthwhile, coupled with a belief in diligence and one’s own efficacy) (National Academies Press, 2001.)

Students are expected to:

1. Make sense of problems and persevere in solving them.

Students begin in elementary school to solve problems by applying their understanding of operations with whole numbers, decimals, and fractions including mixed numbers. Students seek the meaning of a problem and look for efficient ways to represent and solve it. In middle school, students solve real world problems through the application of algebraic and geometric concepts.

2. Reason abstractly and quantitatively.

Earlier grade students should recognize that a number represents a specific quantity. They connect quantities to written symbols and create a logical representation of the problem at hand, considering both the appropriate units involved and the meaning of quantities. They extend this understanding from whole numbers to their work with fractions and decimals. Students write simple expressions that record calculations with numbers and represent or round numbers using place value concepts.

In middle school, students represent a wide variety of real world contexts through the use of real numbers and variables in mathematical expressions, equations, and inequalities. They examine patterns in data and assess the degree of linearity of functions. Students contextualize to understand the meaning of the number or variable as related to the problem and decontextualize to manipulate symbolic representations by applying properties of operations.

3. Construct viable arguments and critique the reasoning of others.

In earlier grades, students may construct arguments using concrete referents, such as objects, pictures, and drawings. They explain calculations based upon models and properties of operations and rules that generate patterns. They demonstrate and explain the relationship between volume and multiplication.

In middle school, students construct arguments using verbal or written explanations accompanied by expressions, equations, inequalities, models, and graphs, tables, and other data displays (e.g., box plots, dot plots, histograms). They further refine their mathematical communication skills through mathematical discussions in which they critically evaluate their own thinking and the

thinking of other students. The students pose questions like “How did you get that?”, “Why is that true?”, and “Does that always work?” They explain their thinking to others and respond to others’ thinking.

4. Model with Mathematics.

Students experiment with representing problem situations in multiple ways including numbers, words (mathematical language), drawing pictures, using objects, making a chart, list, or graph, creating equations, etc. Students need opportunities to connect the different representations and explain the connections. They should be able to use all of these representations as needed. Elementary students should evaluate their results in the context of the situation and whether the results make sense. They also evaluate the utility of models to determine which models are most useful and efficient to solve problems.

In middle school, students model problem situations with symbols, graphs, tables, and context. Students form expressions, equations, or inequalities from real world contexts and connect symbolic and graphical representations. Students solve systems of linear equations and compare properties of functions provided in different forms. Students use scatterplots to represent data and describe associations between variables. Students need many opportunities to connect and explain the connections between the different representations. They should be able to use all of these representations as appropriate to a problem context.

5. Use appropriate tools strategically.

Elementary students consider the available tools (including estimation) when solving a mathematical problem and decide when certain tools might be helpful. For instance, they may use unit cubes to fill a rectangular prism and then use a ruler to measure the dimensions. They use graph paper to accurately create graphs and solve problems or make predictions from real world data.

Students in middle school may translate a set of data given in tabular form to a graphical representation to compare it to another data set. Students might draw pictures, use applets, or write equations to show the relationships between the angles created by a transversal.

6. Attend to precision.

Students in earlier grades continue to refine their mathematical communication skills by using clear and precise language in their discussions with others and in their own reasoning. Students use appropriate terminology when referring to expressions, fractions, geometric figures, and coordinate grids. They are careful about specifying units of measure and state the meaning of the symbols they choose. For instance, when figuring out the volume of a rectangular prism they record their answers in cubic units. Students in middle school use appropriate terminology when referring to the number system, functions, geometric figures, and data displays.

7. Look for and make use of structure.

In elementary grades, students look closely to discover a pattern or structure. For instance, students use properties of operations as strategies to add, subtract, multiply, and divide with whole numbers, fractions, and decimals. They examine numerical patterns and relate them to a rule or a graphical representation.

Students in middle school routinely seek patterns or structures to model and solve problems. Students apply properties to generate equivalent expressions and solve equations. Students examine patterns in tables and graphs to generate equations and describe relationships. Additionally, students experimentally verify the effects of transformations and describe them in terms of congruence and similarity.

8. Look for and express regularity in repeated reasoning.

Students in elementary grades use repeated reasoning to understand algorithms and make generalizations about patterns. Students connect place value and their prior work with operations to understand algorithms, to fluently multiply multi-digit numbers, and to perform all operations with decimals to hundredths. Students explore operations with fractions with visual models and begin to formulate generalizations.

Middle school students use repeated reasoning to understand algorithms and make generalizations about patterns. Students use iterative processes to determine more precise rational approximations for irrational numbers. During multiple opportunities to solve and model problems, they notice that the slope of a line and rate of change are the same value. Students flexibly make connections between covariance, rates, and representations showing the relationships between quantities.

Connecting the Standards for Mathematical Practice to the Content Standards

The Standards for Mathematical Practice describe ways in which developing student practitioners of the discipline of mathematics increasingly should engage with the subject matter as they grow in mathematical maturity and expertise throughout the elementary, middle, and high school years. Designers of curricula, assessments, and professional development should all attend to the need to connect the mathematical practices to mathematical content in instruction.

The Standards for Mathematical Content are a balanced combination of procedure and understanding. Expectations that begin with the word “understand” are often especially good opportunities to connect the practices to the content. Students who are missing the understanding of a topic may rely on procedures too heavily. Without a flexible base from which to work, they may be less likely to consider analogous problems, represent problems coherently, justify conclusions, apply the mathematics to practical situations, use technology mindfully to work with the mathematics, explain the mathematics accurately to other students, step back for an overview, or deviate from a known procedure to find a shortcut. In short, an absence of understanding effectively prevents a student from engaging in the mathematical practices.

In this respect, those content standards which set an expectation of understanding are potential “points of intersection” between the Standards for Mathematical Content and the Standards for Mathematical Practice. These points of intersection are intended to be weighted toward the central and generative concepts in the school mathematics curriculum that most merit the time, resources, innovative energies, and focus necessary to qualitatively improve the curriculum, instruction, assessment, professional development, and student achievement in mathematics. See [Inside Mathematics](#) for more resources.

SELECTED TERMS AND SYMBOLS

The following terms and symbols are often misunderstood. These concepts are not an inclusive list and should not be taught in isolation. However, due to evidence of frequent difficulty and misunderstanding associated with these concepts, instructors should pay particular attention to them and how their students are able to explain and apply them.

The terms below are for teacher reference only and are not to be memorized by the students.

Teachers should present these concepts to students with models and real life examples. Students should understand the concepts involved and be able to recognize and/or demonstrate them with words, models, pictures, or numbers.

- Algebraic Expression
- Area Model
- Array
- Benchmark Fraction
- Coefficient
- Coordinates
- Cubic Number
- Denominator
- Difference
- Digit
- Distributive Property
- Dividend
- Divisor
- Equation
- Equivalent Expressions
- Equivalent Ratios
- Exponent
- Factors
- Formula
- Fraction
- Inequality
- Integer
- Inverse Operations
- Irrational Number
- Numerator
- Numeric Expression
- Opposite of a Number
- Origin
- Product
- Proportional Relationship
- Quadrant
- Quotient
- Rational Number
- Solution
- Square Number
- Substitution
- Sum
- Unit rate
- Variable
- x-axis
- x-coordinate
- y-axis
- y-coordinate

Again, discuss terminology as it naturally arises in discussion of the problems. Allow students to point out words or phrases that lead them to the model and solution of the problems. Words that imply mathematical operations vary based on context and should be delineated based on their use in the particular problem. A couple of suggested methods for students to record vocabulary are TIP Charts (https://www.youtube.com/watch?v=Rbts9h_ruu8) and Frayer Models (<https://wvde.state.wv.us/strategybank/FrayerModel.html>).

The websites below are interactive and include a math glossary suitable for middle school children.

- <http://www.amathsdictionaryforkids.com/>
- <http://intermath.coe.uga.edu/dictionary/homepg.asp>

TABLE OF INTERVENTIONS

<u>Lesson Name</u>	<u>Name Of Intervention</u>	<u>Snapshot of summary or student I can statement ...</u>	<u>Book, Page Or link</u>
Building Number Sense Activities	Addition & Subtraction Pick-n-Mix	Use a range of additive and simple multiplicative strategies with whole numbers, fractions, decimals, and percentages.	Addition & Subtraction Pick-n-Mix
Fact Families	Bowl a Fact	Recall addition and subtraction facts to 20. Recall the multiplication and division facts for the multiples of 2, 3, 5, and 10. Recall multiplication to 10 x 10, and the corresponding division facts.	Bowl a Fact
Is It Reasonable?	Checking Addition and Subtraction by Estimation	Solve addition and subtraction problems by using place value	Checking Addition and Subtraction by Estimation Material Master 8-1
Birthday Cake	Chocolate Chip Cheesecake	Practice multiplying whole numbers by fractions	Chocolate Chip Cheesecake
Fraction Clues	Fractions in a Whole	Find unit fractions of sets using addition facts	Fractions in a Whole
	Hungry Birds	Find unit fractions of sets using addition facts	Hungry Birds
	Fraction Strategies: Wafers	Find unit fractions of sets using addition facts	Fraction Strategies: Wafers
Multiplying Fractions	Multiplying Fractions	Work through some word problems to help increase fluency of multiplying fractions	Multiplying Fractions
Representing Powers of Ten Using Base Ten Blocks	Powers of Powers	Use these activities to help your students develop knowledge of place value and powers of 10 to support multiplicative thinking	Powers of Powers
Multiplying By Powers of Ten	Powers of Powers	Use these activities to help your students develop knowledge of place value and powers of 10 to support multiplicative thinking	Powers of Powers

Georgia Department of Education
 Georgia Standards of Excellence Middle School Support
 GSE Grade 6 • Connections/Support Materials for Remediation

Comparing Decimals	Arrow Cards	Compare Decimals using decimal arrow cards and an understanding of place value.	Arrow Cards Material Master
Integers on the Number Line	Bonus and Penalties	Allow students to build fluency and automatize their use and operations with integers.	Bonus and Penalties
	Array Game	The game allows students to practice their multiplication skills, and reinforces the ‘array’ concept of multiplication	Array Game
Translating Math	Displaying Postcards	Apply algebra to the solution of a problem Devise and use problem solving strategies to explore situations mathematically	Displaying Postcards
Orange Fizz Experiment	Fruit Proportions	Comparing proportions	Fruit Proportions
Which Is The Better Deal?	Percentages Resource Page	A series of 5 activities to help develop automaticity with percentages.	Percentages Resource Page
The Variable Machine	Balancing Acts	The focus here is involving students in solving problems that can be modeled with algebraic equations or expressions. Students are required to describe patterns and relationships using letters to represent variables.	Balancing Acts
	Unknowns and Variables: Solving One Step Equations	The focus of learning is to develop an understanding of the symbols that we use to express our mathematical ideas and to communicate these ideas to others.	Unknowns & Variables: Solving One Step Equations
Don’t Sink My Battleship!	Graphic Detail	Connect members of sequential patterns with their ordinal position and use tables, graphs, and diagrams to find relationships between successive elements of number and spatial patterns	Graphic Detail
	Linear Graphs and Patterns	Relate tables, graphs, and equations	Linear Graphs and Patterns

SCAFFOLDED INSTRUCTIONAL LESSONS

<u>Lesson Name</u>	<u>Lesson Type/ Grouping Strategy</u>	<u>Content Addressed</u>	<u>Standard(s)</u>
<u>Building Number Sense Activities</u>	<i>Partner/Whole Group</i>	Using Basic Number Sense with the Addition, Subtraction, Multiplication, and Division (Whole Numbers)	MFANSQ4.b
<u>Fact Families</u>	<i>Individual</i>	Building arrays and recognizing the fact family (Whole Numbers)	MFANSQ1.a MFANSQ4.b,d
<u>Is It Reasonable?</u>	<i>Individual/Partner</i>	Multiplying and dividing in context problems through estimation, creating equal groups and building models.	MFANSQ1.a MFANSQ4.b,d
<u>Yummy...Chocolate – 3 Act Task</u>	<i>Individual/Partner/ Whole Group</i>	Solving real world problems.	MFANSQ1.a MFANSQ4.b,d
<u>Quick Check</u>	Formative Assessment <i>Individual</i>	Prerequisite knowledge necessary to be successful with fractions (May be used AFTER Birthday Cake depending on your students)	MFANSQ1.b MFANSQ4.b
<u>Birthday Cake</u>	<i>Partner/Group</i>	Determining the fraction of a set, and determine the set when given a fraction.	MFANSQ1.b MFANSQ4.b,c,d
<u>Fraction Clues</u>	<i>Partner</i>	Finding the fraction of a set, the set given a fraction, and equivalent fractions.	MFANSQ1.b MFANSQ4.b,c,d
<u>Multiplying Fractions</u>	<i>Individual/Partner</i>	Representing multiplication of fractions using a model.	MFANSQ1.b MFANSQ4.b,c,d
<u>Birthday Cookout</u>	<i>Individual/Partner</i>	Solving story problems that involve the multiplication of fractions.	MFANSQ1.b MFANSQ4.b,c,d

Georgia Department of Education
 Georgia Standards of Excellence Middle School Support
 GSE Grade 6 • Connections/Support Materials for Remediation

<u>Lesson Name</u>	<u>Lesson Type/ Grouping Strategy</u>	<u>Content Addressed</u>	<u>Standard(s)</u>
<u>Representing Powers of Ten Using Base Ten Blocks</u>	<i>Individual/Partner</i>	Multiplying and dividing by a power of ten.	MFANSQ1.c,d MFANSQ4.a,b,d
<u>Multiplying by Powers of Ten</u>	<i>Individual/Whole Group</i>	Multiplying and dividing by a power of ten.	MFANSQ1.c,d MFANSQ4.a,b,d
<u>Comparing Decimals</u>	<i>Individual/Partner</i>	Comparing decimals.	MFANSQ1.d MFANSQ4.a,b,d
<u>Integers on the Number Line</u>	<i>Partner/Whole Group</i>	Identifying integers and their placement on the number line.	MFANSQ2.a,b,c MFANSQ4.a,b,d
<u>Translating Math</u>	Constructing Lesson <i>Individual/Partner</i>	Verbal expressions into symbolic representation Simplify Expressions	MFAAA1.e
<u>The Algebra of Magic</u>	3 Act Task/ <i>Individual/Partner and/or Small Group</i>	Simplification Review	MFAAA1
<u>Orange Fizz Experiment</u>	Learning Lesson <i>Partners or small groups</i>	Examine part-to-part and part-to-whole comparisons in order to make decisions	MFAPR.1 MFAPR.2
<u>Which Is the Better Deal?</u>	Learning Lesson <i>Partners or small groups</i>	Compare unit rates to make purchasing decisions	MFAPR.2
<u>“Illustrative” Review 1</u>	Formative Assessment <i>Individual</i>	A compilation of problem related to percentages, slopes, and rates.	MFAPR.2 MFAPR.3
<u>The Variable Machine</u>	Constructing Lesson <i>Individual/Partner</i>	Introducing the use of variables	MFAEI1.a, e
<u>“Illustrative” Review 2</u>	Formative Assessment <i>Individual</i>	A compilation of expressions, equations, and inequalities.	
<u>Don’t Sink My Battleship!</u>	Constructing Lesson <i>Partner/Small Group</i>	Graphing ordered pairs in the coordinate system; using coordinates as locations	MFAEI2.b, c

Building Number Sense Activities

Adapted from Teaching Student-Centered Mathematics: Grades 3-5 by John A. Van de Walle.

The purpose of the activities in this lesson is to provide students the opportunity to build their conceptual understanding of whole numbers, look at computation in a different light and ultimately gain confidence in their number sense. *These activities would be a great way to start class each day.*

SUGGESTED TIME FOR THIS LESSON:

5-10 minutes every day
Exact timings will depend on the needs of your class.

STANDARDS FOR MATHEMATICAL CONTENT

Students will compare different representations of numbers (i.e., fractions, decimals, radicals, etc.) and perform basic operations using these different representations.

- MFANSQ4.** Students will apply and extend previous understanding of addition, subtraction, multiplication, and division.
- b. Find sums, differences, products, and quotients of all forms of rational numbers, stressing the conceptual understanding of these operations. (MGSE7.NS.1,2)

STANDARDS FOR MATHEMATICAL PRACTICE

1. Make sense of problems and persevere in solving them. High school students start to examine problems by explaining to themselves the meaning of a problem and looking for entry points to its solution. They analyze givens, constraints, relationships, and goals. They make conjectures about the form and meaning of the solution and plan a solution pathway rather than simply jumping into a solution attempt. They consider analogous problems, and try special cases and simpler forms of the original problem in order to gain insight into its solution. They monitor and evaluate their progress and change course if necessary. Older students might, depending on the context of the problem, transform algebraic expressions or change the viewing window on their graphing calculator to get the information they need. By high school, students can explain correspondences between equations, verbal descriptions, tables, and graphs or draw diagrams of important features and relationships, graph data, and search for regularity or trends. They check their answers to problems using different methods and continually ask themselves, “Does this make sense?” They can understand the approaches of others to solving complex problems and identify correspondences between different approaches.

4. Model with mathematics. High school students can apply the mathematics they know to solve problems arising in everyday life, society, and the workplace. By high school, a student might use geometry to solve a design problem or use a function to describe how one quantity of interest depends on another. High school students making assumptions and approximations to simplify a complicated situation, realizing that these may need revision later. They are able to identify

important quantities in a practical situation and map their relationships using such tools as diagrams, two-way tables, graphs, flowcharts and formulas. They can analyze those relationships mathematically to draw conclusions. They routinely interpret their mathematical results in the context of the situation and reflect on whether the results make sense, possibly improving the model if it has not served its purpose.

7. Look for and make use of structure. By high school, students look closely to discern a pattern or structure. In the expression $x^2 + 9x + 14$, older students can see the 14 as 2×7 and the 9 as $2 + 7$. They recognize the significance of an existing line in a geometric figure and can use the strategy of drawing an auxiliary line for solving problems. They also can step back for an overview and shift perspective. They can see complicated things, such as some algebraic expressions, as single objects or as being composed of several objects. For example, they can see $5 - 3(x - y)^2$ as 5 minus a positive number times a square and use that to realize that its value cannot be more than 5 for any real numbers x and y . High school students use these patterns to create equivalent expressions, factor and solve equations, and compose functions, and transform figures.

8. Look for and express regularity in repeated reasoning. High school students notice if calculations are repeated, and look both for general methods and for shortcuts. Noticing the regularity in the way terms cancel when expanding $(x - 1)(x + 1)$, $(x - 1)(x^2 + x + 1)$, and $(x - 1)(x^3 + x^2 + x + 1)$ might lead them to the general formula for the sum of a geometric series. As they work to solve a problem, derive formulas or make generalizations, high school students maintain oversight of the process, while attending to the details. They continually evaluate the reasonableness of their intermediate results.

EVIDENCE OF LEARNING/LEARNING TARGET

By the conclusion of this lesson, students should be able to:

- Recognize numbers quickly.
- Represent numbers in multiple ways.
- Fluently add and subtract whole numbers.
- Find products.
- Divide whole numbers.

Building Number Sense – Addition and Subtraction Activities

- Tell About It
- Battle of the Ten Frames (Game)
- 50 and Some More
- Compatible Pairs
- Sushi Monster (Game – Available on the App Store on iTunes)

ESSENTIAL QUESTIONS

- How can you represent a number in a variety of ways?
- How can you find the sum?
- How can you find the difference?

TEN FRAME ACTIVITIES

- Tell About It
- Battle of the Ten Frames

The objective of the ten frame activities is for students to build relationships with the anchor numbers of 5 and 10. The following video can be used to obtain a snapshot of a classroom implementing a Number Talk.

Video: Number Talks - **Math Perspectives: AMC Ten Frames Assessment**
<https://www.youtube.com/watch?v=FGfj9oPaJW0>

MATERIALS

- Ten Frames (a set is provided at the end of this section)

TELL ABOUT IT

Grouping: Partners; Whole Group

Directions:

Give each student a card or project a card for the whole class to view. Ask the student(s), “What number do you see?” Then ask, “How could you write that number differently given this ten frame?”

Possible answers: It is 7. It is 3 away from 10, 2 more than 5, or someone may see it as a group of 4 plus 3 more which is fine but encourage 5's and 10's. They are "nice numbers" which are easy to work with.

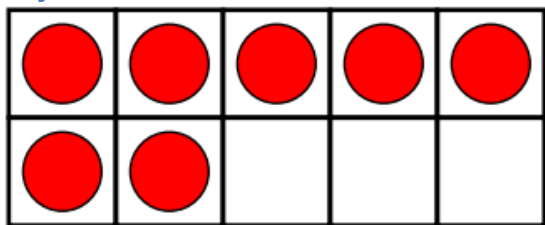

Possible answers: It is 5. It is 5 away from 10.

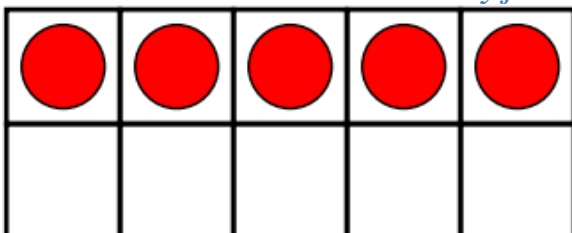

Possible answers: It is 9. It is 1 away from 10, 4 more than 5.

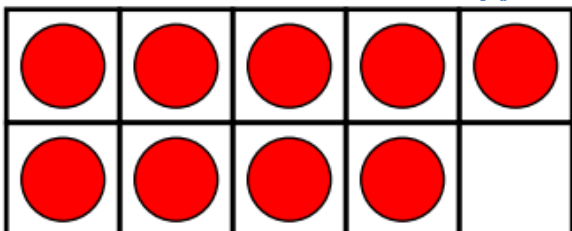

BATTLE OF THE TEN FRAMES: Adding and Subtracting

Grouping: Partners

Directions:

Provide each student a deck of cards 1-10. Each student will place a card down. The student with correct sum first wins the pair. (Alternate Version: Subtraction)

Whole Class Addition Version: <https://www.youtube.com/watch?v=AVjvswqL-Ow>

Georgia Department of Education
Georgia Standards of Excellence Middle School Support
GSE Grade 6 • Connections/Support Materials for Remediation

●				

●	●			

●	●	●		

Georgia Department of Education
Georgia Standards of Excellence Middle School Support
GSE Grade 6 • Connections/Support Materials for Remediation

●	●	●	●	

●	●	●	●	●

●	●	●	●	●
●				

Georgia Department of Education
Georgia Standards of Excellence Middle School Support
GSE Grade 6 • Connections/Support Materials for Remediation

●	●	●	●	●
●	●			

●	●	●	●	●
●	●	●		

●	●	●	●	●
●	●	●	●	

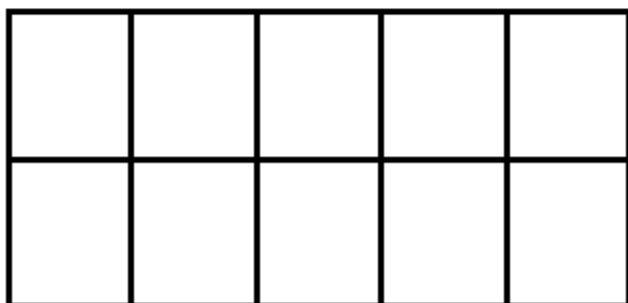
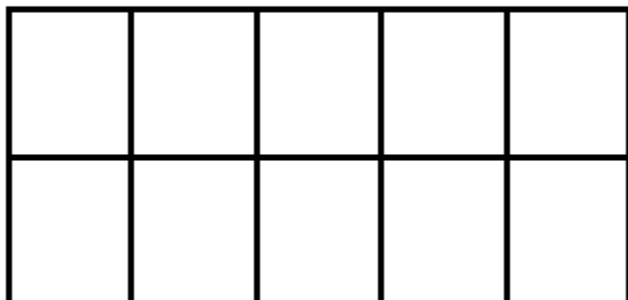
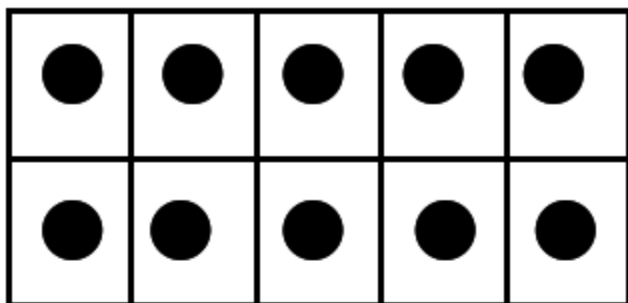

50 AND SOME MORE

Grouping: Whole Group

Materials:

- none

Directions:

Say a number to the class. You can call on people or ask for volunteers. The student's response should be "50 and ____". For example, if the number is 72 they would say "50 and 22." If the number were, 39 then the student would say "50 and -11." You should probably start out with number greater than 50 then work to numbers less than 50 by the end of the course. This is a great time filler with a purpose. This activity could also work with 100. Again notice the anchor numbers of "5 and 10."

COMPATIBLE PAIRS

Grouping: Individual; Partners

Materials:

- WS/Card prepared by the teacher

Directions:

Provide students with a group of numbers. From the group of numbers given, students are to complete the lesson. See the example below where students are asked to make pairs that have a sum of 100. This is a great activity for **whole numbers, integers, fractions, or decimals**. The teacher can also vary the operation.

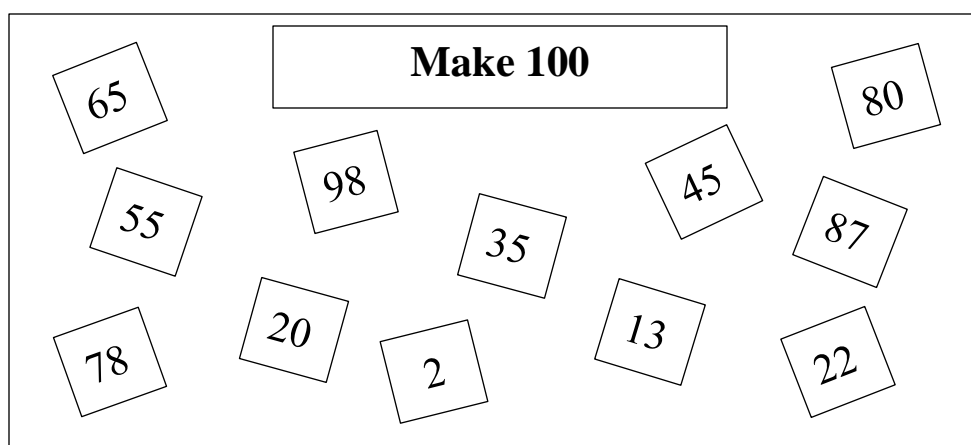

SUSHI MONSTER

Grouping: Individual

The Sushi Monster App can be found on the App Store on iTunes and is free. The app encourages practice in either addition or multiplication.

INTERVENTION

For extra help with addition and subtraction, please open the hyperlink [Intervention Table](#).

Building Number Sense – Multiplication & Division

- Finding Factors
- Divide It Up
- Slice It Up
- Impoppable (Game – Available on the App Store on iTunes)
- Sushi Monster (Game – Available on the App Store on iTunes)

ESSENTIAL QUESTIONS

- How can you represent a number in a variety of ways?
- How can you find the factors of a given product?
- How can you find the product?

FINDING FACTORS

Grouping: Individual

Materials

- Grid Paper
- Color Tiles

Directions:

Assign each student a number that has several factors. Have them create a variety of models for those factors. (For Example – arrays, use of the numbers, drawing sets)

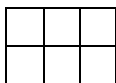

2 by 3 is 6

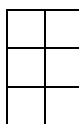

3 by 2 is 6

DIVIDE IT UP

Grouping: Individual; Partners

Materials:

- Color Tiles

Directions:

Assign each student a number and that number of colored tiles. Tell the students how many equal sets you want or the number that should be in each. The students should then divide out the tiles to see if they can make equal sets. Have the student write the fact family if possible.

Example: Given the number 12. A student may make 3 equal sets with 4 tiles in each group. Fact family would be $3 \times 4 = 12$, $4 \times 3 = 12$, and $12 \div 3 = 4$, $12 \div 4 = 3$

SLICE IT UP (Distributive Property)

Grouping: Individual; Partners

Materials:

- Grid Paper

Directions:

Give each student an array. Have them slice it up. For example, an 8×10 array may be sliced so that it shows a 6×10 and 2×10 . $8 \times 10 = (6 \times 10) + (2 \times 10)$

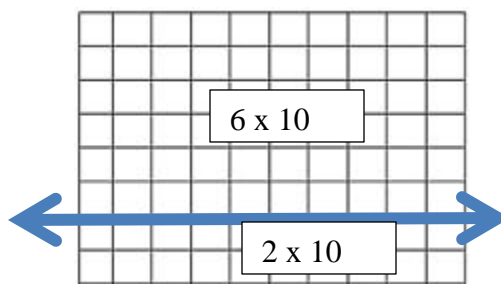

IMPOPPABLE

Grouping: Individual

The Impoppable App can be found on the App Store on the iTunes and is free. The app encourages the use of fact families. Students are to quickly pop bubbles in order 3, 5, 15 (multiplication) or 15, 3, 5 (division). As you progress in the levels more fact families are added.

SUSHI MONSTER

Grouping: Individual

The Sushi Monster App can be found on the App Store on the iTunes and is free. The app encourages practice in either addition or multiplication.

INTERVENTIONS

For extra help with operations, please open the hyperlink [Intervention Table](#).

Fact Families

SUGGESTED TIME FOR THIS LESSON:

60-90 minutes

Exact timings will depend on the needs of your class.

STANDARDS FOR MATHEMATICAL CONTENT

Students will compare different representations of numbers (i.e., fractions, decimals, radicals, etc.) and perform basic operations using these different representations.

MFANSQ1. Students will analyze number relationships.

a. Solve multi-step real world problems, analyzing the relationships between all four operations. For example, understand division as an unknown-factor problem in order to solve problems. Knowing that $50 \times 40 = 2000$ helps students determine how many boxes of cupcakes they will need in order to ship 2000 cupcakes in boxes that hold 40 cupcakes each. (MGSE3.OA.6, MGSE4.OA.3)

MFANSQ4. Students will apply and extend previous understanding of addition, subtraction, multiplication, and division.

b. Find sums, differences, products, and quotients of all forms of rational numbers, stressing the conceptual understanding of these operations. (MGSE7.NS.1,2)

d. Illustrate and explain calculations using models and line diagrams. (MGSE7.NS.1,2)

Common Misconceptions

- *Students may have difficulty seeing multiplication and division as inverse operations. In order to develop an understanding of this relationship, students need to have ample opportunities to explore these two operations simultaneously.*
- *When listing multiples of numbers, students may not list the number itself. Emphasize that the smallest multiple is the number itself.*
- *Some students may think that larger numbers have more factors. Having students share all factor pairs and how they found them will clear up this misconception.*
- *Some students may need to start with numbers that only have one pair of factors, then those with two pairs of factors before finding factors of numbers with several factor pairs.*

STANDARDS FOR MATHEMATICAL PRACTICE

- 1. Make sense of problems and persevere in solving them.** Students solve problems by applying and extending their understanding of multiplication and division to decimals. Students seek the meaning of a problem and look for efficient ways to solve it. They determine where to place the decimal point in calculations.
- 2. Reason abstractly and quantitatively.** Students demonstrate abstract reasoning to connect decimal quantities to fractions, and to compare relative values of decimal numbers. Students round decimal numbers using place value concepts.
- 3. Construct viable arguments and critique the reasoning of others.** Students construct arguments using concrete referents, such as objects, pictures, and drawings. They explain calculations and placement of the decimal point, based upon models and rules that generate patterns. They explain their thinking to others and respond to others' thinking.
- 4. Model with mathematics.** Students use base ten blocks, drawings, number lines, and equations to represent decimal place value, multiplication and division. They determine which models are most efficient for solving problems.
- 5. Use appropriate tools strategically.** Students select and use tools such as graph or grid paper, base ten blocks, and number lines to accurately solve multiplication and division problems with decimals.
- 6. Attend to precision.** Students use clear and precise language, (math talk) in their discussions with others and in their own reasoning. Students use appropriate terminology when referring to decimal place value and use decimal points correctly.
- 7. Look for and make use of structure.** Students use properties of operations as strategies to multiply and divide with decimals. Students utilize patterns in place value and powers of ten to correctly place the decimal point.
- 8. Look for and express regularity in repeated reasoning.** Students use repeated reasoning to understand algorithms and make generalizations about patterns. Students connect place value and properties of operations to fluently multiply and divide decimals.

EVIDENCE OF LEARNING/LEARNING TARGET

By the conclusion of this lesson, students should be able to:

Represent multiplication and division using a rectangular array model.

- Represent a number in a variety of mathematical sentences.
- Solve real world problems using strategies.

MATERIALS

- Grid paper
- Color pencils
- “Array-ning Our Fact Families” recording sheet
- Color Tiles (optional for tactile learners)

ESSENTIAL QUESTIONS

- How are multiplication and division related?
- How can the same array represent both multiplication and division?

Grouping: Individual/Partner

OPENER/ACTIVATOR

Have students look at the picture of chocolates. Ask the students “How many do you see? How do you see them?”



Students may respond: 6 chocolates

*3 rows of 2 in each row
2 columns of 3 in each column
2 groups of 3
3 groups of 2
3 x 2
2 x 3*

Again have the students view the second picture of chocolate. Ask the students “How many chocolates are in this picture? How do you know?”



Students may respond: 12 chocolates

*3 rows of 4 in each row
4 columns of 3 in each column
4 groups of 3
3 groups of 4
3 x 4
4 x 3*

Student Page: Opener/Activator



How many do you see? How do you see them?



How many chocolates are in this picture? How do you know?

WORK SESSION

PART 1

Using the grid paper and colored pencils, have students create as many arrays possible using 12 squares. Is there a relationship between of the arrays drawn? (i.e. 3 by 4 array is the same as 4 by 3 array)

Have the students write a multiplication sentence for each array. Ask students to write a division sentence with the dividend represented by the total area of the array. For example, a student may make a 4 x 3 array. The dividend (area of 12) can be divided by 4 or 3 both factors of 12. Both dimensions are utilized, one as the divisor and the other as the quotient.

$3 \times 4 = 12$
$4 \times 3 = 12$
$12 \div 3 = 4$
$12 \div 4 = 3$

Another array may be a 2 by 6:
$2 \times 6 = 12$
$6 \times 2 = 12$
$12 \div 2 = 6$
$12 \div 6 = 2$

PART 2

Teacher Key

Students will follow the directions below from the “Array-ning Our Fact Families” recording sheet.

1. Draw the following arrays:

6 by 3

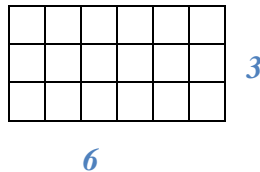

$6 \times 3 = 18$
$3 \times 6 = 18$
$18 \div 3 = 6$
$18 \div 6 = 3$

4 by 8

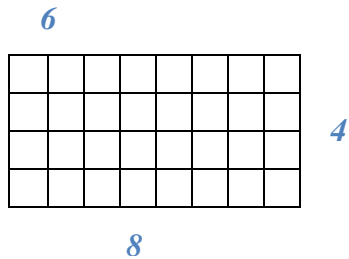

$8 \times 4 = 32$
$4 \times 8 = 32$
$32 \div 8 = 4$
$32 \div 4 = 8$

2 by 7

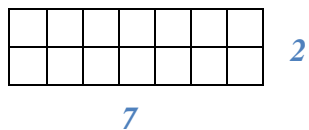

$2 \times 7 = 14$
$7 \times 2 = 14$
$14 \div 2 = 7$
$14 \div 7 = 2$

2. Use the example to complete the following for each array:

- Label the dimensions and total area. *See answers above.*
- Write a multiplication sentence and label the factors and the product. *See answers above.*
- Write a division sentence and label the divisor, dividend, and quotient. *See answers above.*

3. Select one of your arrays and write two story problems that can be modeled with the array, one for multiplication and one for division.

Answers may vary.

Strategies for Teaching and Learning: The use of mathematical vocabulary can shy students away from story problems, so encourage students to use the appropriate vocabulary when discussing the fact families. For example, “the factors of 4 and 3 result in a product of 12” or “3 is the quotient of ‘ $12 \div 4$ ’”.

Differentiation: Allow students to build an array of their choice, but limit them to not larger than a 3 digit by 1 digit.

Technology: Impoppable

The Impoppable App can be found on the App Store on the iTunes and is free. The app encourages the use of fact families. Students are to quickly pop bubbles in order 3, 5, 15 (multiplication) or 15, 3, 5 (division). As you progress in the levels more fact families are added.

INTERVENTIONS

For extra help with number facts, please open the hyperlink [Intervention Table](#).

Name _____ Date _____



Array-ning Our Fact Families

This 3 by 5 array has a total of 15 square units.
 $3 \times 5 = 15$.

3 and 5 are **factors**.
 15 is the **product**.

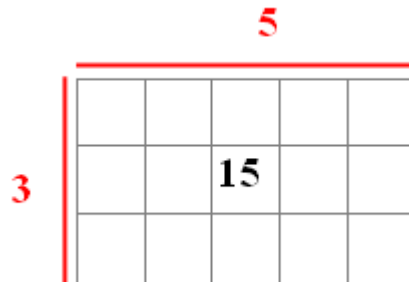

Fifteen divided by three equals five.
 $15 \div 3 = 5$
 15 is the **dividend**.
 3 is the **divisor**.
 5 is the **quotient**.

1. Draw the following arrays listed in the table below.
2. Following the example above, complete the following for each array:
 - Label the dimensions and total area.
 - Write a multiplication sentence and label the factors and the product.
 - Write a division sentence and label the divisor, dividend, and quotient.

6 by 3	4 by 8	2 by 7
--------	--------	--------

3. Select one of your arrays. On the back of this paper, write two story problems that can be modeled with the array, one for multiplication and one for division.

CLOSING/SUMMARIZER

Given the picture of Swiss Miss, write the fact family and a story problem.



Student Work: CLOSING/SUMMARIZER



Given the picture of Swiss Miss, write the fact family and a story problem.

Additional Practice Problems:

1. The vending machine has been loaded up with Mrs. Lane's favorite candy, Peanut Butter Cups. If there are 9 sections of Peanut Butter Cups and each one holds 12, how many days can you keep Mrs. Lane happy if you give her one each day?

9 sections x 12 Peanut Butter Cups = (9 x 10) + (9 x 2) = 90 + 18 = 108 days

2. The time has come to purchase your parking pass for school. The student parking lot consists of 6 rows which hold 34 cars each. There are 200 students at your school that can drive. How many will not be able to park at school?

6 rows x 34 cars = (6 x 30) + (6 x 4) = 180 + 24 = 204 spaces in the lot

So there are actually 4 extra spaces.

Zero – everyone will be able to park.

3. Your teacher wants to make sure everyone has a pencil for class. She has 104 students in all of her classes. The office gave her 4 boxes of pencils. How many pencils were in each box if each of her students receives 1 pencil?

104students ÷ 4boxes of pencils = (100 ÷ 4) + (4 ÷ 4) = 25 + 1 = 26 pencils in each box

4. Your class is collecting bottled water for a service project. The goal is to collect 300 bottles of water. On the first day, Max brings in 3 packs with 6 bottles in each pack. Sarah wheels in 6 packs with 12 bottles in each pack. About how many bottles of water still need to be collected?

Max 3 packs x 6 bottles/pack = 18 bottles

Sarah 6 packs x 12 bottles/pack = 72

18 + 72 = 90 bottles (Mentally the student may think (10+70) = (8+2) = 80+10 = 90)

300 – 90 = 210 bottles (Mentally using compatible numbers 300 – 100 = 200 + 10)

Is It Reasonable?

SUGGESTED TIME FOR THIS LESSON:

50-60 minutes

Exact timings will depend on the needs of your class.

STANDARDS FOR MATHEMATICAL CONTENT

Students will compare different representations of numbers (i.e., fractions, decimals, radicals, etc.) and perform basic operations using these different representations.

MFANSQ1. Students will analyze number relationships.

a. Solve multi-step real world problems, analyzing the relationships between all four operations. For example, understand division as an unknown-factor problem in order to solve problems. Knowing that $50 \times 40 = 2000$ helps students determine how many boxes of cupcakes they will need in order to ship 2000 cupcakes in boxes that hold 40 cupcakes each. (MGSE3.OA.6, MGSE4.OA.3)

MFANSQ4. Students will apply and extend previous understanding of addition, subtraction, multiplication, and division.

b. Find sums, differences, products, and quotients of all forms of rational numbers, stressing the conceptual understanding of these operations. (MGSE7.NS.1,2)

d. Illustrate and explain calculations using models and line diagrams. (MGSE7.NS.1,2)

Common Misconceptions:

- *Students tend to not ask themselves if the answer fits the situation. They feel the result of their calculations must be true for any given situation.*
- *Students do not realize there are situations when you must round up even if the decimal is less than five-tenths.*

STANDARDS FOR MATHEMATICAL PRACTICE

1. Make sense of problems and persevere in solving them. Students solve problems by applying and extending their understanding of multiplication and division to decimals. Students seek the meaning of a problem and look for efficient ways to solve it. They determine where to place the decimal point in calculations.

2. Reason abstractly and quantitatively. Students demonstrate abstract reasoning to connect decimal quantities to fractions, and to compare relative values of decimal numbers. Students round decimal numbers using place value concepts.

3. Construct viable arguments and critique the reasoning of others. Students construct arguments using concrete referents, such as objects, pictures, and drawings. They explain calculations and placement of the decimal point, based upon models and rules that generate patterns. They explain their thinking to others and respond to others' thinking.

4. Model with mathematics. Students use base ten blocks, drawings, number lines, and equations to represent decimal place value, multiplication and division. They determine which models are most efficient for solving problems.

5. Use appropriate tools strategically. Students select and use tools such as graph or grid paper, base ten blocks, and number lines to accurately solve multiplication and division problems with decimals.

6. Attend to precision. Students use clear and precise language, (math talk) in their discussions with others and in their own reasoning. Students use appropriate terminology when referring to decimal place value and use decimal points correctly.

7. Look for and make use of structure. Students use properties of operations as strategies to multiply and divide with decimals. Students utilize patterns in place value and powers of ten to correctly place the decimal point.

EVIDENCE OF LEARNING/LEARNING TARGET

By the conclusion of this lesson, students should be able to:

- Estimate and find the product of a 2- digit number multiplied by a 2-digit number.
- Represent multiplication and division using a rectangular area model.
- Understand that multiplication may be used in problem contexts involving equal groups, rectangular arrays/area models, or rate.
- Solve division problems using strategies.
- Divide whole-numbers quotients and remainders with up to four-digit dividends and remainders with up to four-digit dividends and one-digit divisors.

MATERIALS

- “Compatible Numbers” Recording Sheet

ESSENTIAL QUESTIONS

- How are multiplication and division related to each other?
- What are some simple methods for solving multiplication and division problems?
- What patterns of multiplication and division can assist us in problem solving?
- How can you mentally compute a division problem?
- What are compatible numbers and how do they aid in dividing whole numbers?

Grouping: Individual/Partner

OPENER/ACTIVATOR

Pose this question: (No Paper/Pencil Allowed)

There are 592 students participating in Field Day. They are put into teams of 8 for the competition. How many teams are there?

Comments

The understanding of the relationship that exists between multiplication and division is critical for students to know as well as the strong relationship between the dividend, divisor, and quotient. This lesson is designed to allow students to further explore these relationships.

Possible answers:

<u><i>Student 1</i></u>	<u><i>Student 2</i></u>	<u><i>Student 3</i></u>
<p><i>592 divided by 8</i> <i>There are 70 8's in 560</i> $592 - 560 = 32$ <i>There are 4 8's in 32</i> $70 + 4 = 74$</p>	<p><i>592 divided by 8</i> <i>I know that 10 8's is 80</i> <i>If I take out 50 8's that is 400</i> $592 - 400 = 192$ <i>I can take out 20 more 8's</i> <i>which is 160</i> $192 - 160 = 32$ <i>8 goes into 32 4 times</i> <i>I have none left</i> <i>I took out 50, then 20 more,</i> <i>then 4 more</i> <i>That is 74</i></p>	<p><i>I want to get to 592</i> $8 \times 25 = 200$ $8 \times 25 = 200$ $8 \times 25 = 200$ $200 + 200 + 200 = 600$ $600 - 8 = 592$ <i>I had 75 groups of 8</i> <i>and took one away, so</i> <i>there are 74 teams</i></p>

WORK SESSION:

NUMBER TALKS

Several Number Talks strategies can help student build a stronger understanding of division. Repeated subtraction, partial quotients, multiplying up and proportional reasoning are all valuable strategies that students can explore through number talks. For more information, refer to pages 286-299 in *Number Talks*. (Number Talks, 2010, Sherry Parrish)

LESSON DESCRIPTION, DEVELOPMENT, AND DISCUSSION

Comments

Ask students how they could estimate the number of small prizes each of Mr. Wong’s 9 students would receive if he had exactly 893 prizes to give away. If no one mentions compatible numbers, remind the class that they can estimate the answer to a problem by replacing the numbers in the problem with numbers that are easier to calculate with. Such easier numbers are called compatible numbers. You might show this example of compatible numbers:

- To estimate $3,456 \div 7$, students might recognize 3,456 is close to 3,500 and choose compatible numbers 3,500 and 7. So, $3,456 \div 7$ is about $3,500 \div 7$, or 500.

Lesson Directions/Answers

Students will follow the directions below from the “Compatible Numbers” recording sheet.

1. Mr. Wong has between 300 and 1,000 small prizes to divide evenly among his 9 students over the course of the school year. He will give away as many prizes as possible. Estimate the number of small prizes each of Mr. Wong’s 9 students would receive if he had exactly 893 prizes to give away.

$$893 \div 9 \approx 900 \div 9 \approx 100 \text{ prizes/student}$$

2. At Hatfield Elementary School, there are 504 students in 7 classes. Each class has the same number of students. What is a good estimate of the number of students in each class? Explain your reasoning.

$$504 \div 7 = (490 \div 7) + (14 \div 7) = 70 \text{ students} + 2 \text{ students} = 72 \text{ students}$$

3. Marcel worked 9 hours and earned \$232. What is a good estimate of the amount that he earned each hour? Explain your reasoning.

$$\$232 \div 9$$

$$\$180 \div 9 = 20 \text{ leaving } \$52 \div 9 \approx \$54 \div 9 = 6 \text{ so } \$20 + \$6 = \text{about } \$26/\text{hr}$$

Or

$$\text{Estimating } \$230 \div 10 = \$23 \text{ which is low; therefore, we could estimate about } \$25/\text{hr}$$

FORMATIVE ASSESSMENT QUESTIONS

- What compatible numbers are you using?
- How did these compatible numbers make solve the problem easier?
- Do you think that is a reasonable estimate? Why?

DIFFERENTIATION

Extension

Have students solve the following problem with an estimate which fits the context. Mr. Wong has between 300 and 1,000 small prizes to divide evenly among his 9 students over the course of the school year. He will give away as many prizes as possible. What is the greatest number of prizes that could be left over? Is it possible for each student to get 200 prizes?

Intervention

Have students link basic division facts to identifying compatible numbers. You can begin with $35 \div 7$, then $350 \div 7$. Make explicit the connection of the compatibility between 35 and 7 and how it can be applied to 350 and 7.

For extra help with estimation, please open the hyperlink [Intervention Table](#).

TECHNOLOGY

<http://www.bbc.co.uk/schools/ks1bitesize/numeracy/division/index.shtml> provides differentiated activities for 3 levels and can be used for remediation or additional practice.

http://www.thinkingblocks.com/mathplayground/tb_md/tb_md5.html Watch a short video that explains how to use thinking blocks to interpret remainders when solving division word problems. Then, practice modeling and solving problems. The video can be used to show other strategies for dividing or as an introduction to the lesson.

<http://illuminations.nctm.org/activity.aspx?id=4197> is a game which can be used to practice the concept of division.

CLOSING/SUMMARIZER

Journal Ideas:

- Explain how compatible numbers are used to solve problems efficiently.
- Write a story problem in which one might use compatible numbers to solve.

Additional Practice:

1. There are 128 students going on a field trip. If each bus held 30 students, how many buses are needed?

$128 \div 30 \approx 120 \div 30 \approx 4$ buses with 8 students leftover; therefore, 5 buses are needed

2. Chris bought clothes for school. She bought 3 shirts for \$12 each and a skirt for \$15. How much money did Chris spend on her new school clothes?

$3 \text{ shirts} \times \$12 = \$36$ on shirts

$\$36 + \$15 = (\$30 + \$10) + (\$6 + \$5) = \$40 + \$11 = \$51$ on new clothes

3. Kim is making candy bags. There will be 5 pieces of candy in each bag. She had 53 pieces of candy. She ate 14 pieces of candy. How many candy bags can Kim make now?

$53 - 14 = 39$ pieces of candy left to make bags

(Mentally the student may have thought $54 - 14 = 40 - 1 = 39$)

$39 \div 5$ is close to $40 \div 5$ which is 8 but we rounded up so we can only make 7 bags.

4. Write different word problems involving $44 \div 6 = ?$ where the answers are best represented as:
 - a. Problem A: 7
 - b. Problem B: 7 r 2
 - c. Problem C: 8
 - d. Problem D: 7 or 8
 - e. Problem E: $7\frac{2}{6}$

Answers may vary.

Student Edition: Additional Practice:

1. There are 128 students going on a field trip. If each bus held 30 students, how many buses are needed?

2. Chris bought clothes for school. She bought 3 shirts for \$12 each and a skirt for \$15. How much money did Chris spend on her new school clothes?

3. Kim is making candy bags. There will be 5 pieces of candy in each bag. She had 53 pieces of candy. She ate 14 pieces of candy. How many candy bags can Kim make now?

4. Write different word problems involving $44 \div 6 = ?$ where the answers are best represented as:
 - a. Problem A: 7
 - b. Problem B: 7 r 2
 - c. Problem C: 8
 - d. Problem D: 7 or 8
 - e. Problem E: $7\frac{2}{6}$

Yummy...Chocolate – 3 Act Task

SUGGESTED TIME FOR THIS LESSON:

60-90 minutes

Exact timings will depend on the needs of your class.

STANDARDS FOR MATHEMATICAL CONTENT

Students will compare different representations of numbers (i.e., fractions, decimals, radicals, etc.) and perform basic operations using these different representations.

MFANSQ1. Students will analyze number relationships.

a. Solve multi-step real world problems, analyzing the relationships between all four operations. For example, understand division as an unknown-factor problem in order to solve problems. Knowing that $50 \times 40 = 2000$ helps students determine how many boxes of cupcakes they will need in order to ship 2000 cupcakes in boxes that hold 40 cupcakes each. (MGSE3.OA.6, MGSE4.OA.3)

MFANSQ4. Students will apply and extend previous understanding of addition, subtraction, multiplication, and division.

b. Find sums, differences, products, and quotients of all forms of rational numbers, stressing the conceptual understanding of these operations. (MGSE7.NS.1,2)

d. Illustrate and explain calculations using models and line diagrams. (MGSE7.NS.1,2)

STANDARDS FOR MATHEMATICAL PRACTICE

1. Make sense of problems and persevere in solving them. Students solve problems by applying and extending their understanding of multiplication and division to decimals. Students seek the meaning of a problem and look for efficient ways to solve it. They determine where to place the decimal point in calculations.

2. Reason abstractly and quantitatively. Students demonstrate abstract reasoning to connect decimal quantities to fractions, and to compare relative values of decimal numbers. Students round decimal numbers using place value concepts.

3. Construct viable arguments and critique the reasoning of others. Students construct arguments using concrete referents, such as objects, pictures, and drawings. They explain calculations and placement of the decimal point, based upon models and rules that generate patterns. They explain their thinking to others and respond to others' thinking.

4. Model with mathematics. Students use base ten blocks, drawings, number lines, and equations to represent decimal place value, multiplication and division. They determine which models are most efficient for solving problems.

5. Use appropriate tools strategically. Students select and use tools such as graph or grid paper, base ten blocks, and number lines to accurately solve multiplication and division problems with decimals.

6. Attend to precision. Students use clear and precise language, (math talk) in their discussions with others and in their own reasoning. Students use appropriate terminology when referring to decimal place value and use decimal points correctly.

7. Look for and make use of structure. Students use properties of operations as strategies to multiply and divide with decimals. Students utilize patterns in place value and powers of ten to correctly place the decimal point.

8. Look for and express regularity in repeated reasoning. Students use repeated reasoning to understand algorithms and make generalizations about patterns. Students connect place value and properties of operations to fluently multiply and divide decimals.

EVIDENCE OF LEARNING/LEARNING TARGET

By the conclusion of this lesson, students should be able to solve real world problems.

MATERIALS

Pictures of Ferrero Rocher Chocolates

ESSENTIAL QUESTIONS

How can you solve real world problems?

Grouping: Individual/Partner/Whole Group

OPENER/ACTIVATOR

ACT ONE:

Provide students with this information:



At Sam's Club, 21.1 ounces of
Ferrero Rocher Chocolates
costs \$13.46.
Grade Level: 526 students

Teacher Notes: Brainstorm questions one might ask given this information.

- *How many boxes must you buy to purchase one chocolate for every student?*
- *How many ounces would each student get?*
- *What is the cost per student?*

WORK SESSION:

ACT TWO:

Given the strategies to find compatible numbers, build arrays, and groups, show how you could solve this problem:

Can you justify this cost to treat each of your students one Ferrero Rocher Chocolate to celebrate the end of testing?

The box of chocolates is a 4 by 6 array; therefore, there are 24 chocolates per box.

$526 \div 24$ is about $525 \div 25$ (thinking of money) = There are 20 quarters in \$5 and 1 quarter in 25 cents. This is 21 boxes; however, you need 1 more box because there are only 24 in the box not 25. You need 22 boxes.

Task Title: _____

Name: _____

Adapted from Andrew Stadel

ACT 1

What did/do you notice?

What questions come to your mind?

Main Question: _____

Estimate the result of the main question? Explain?

Place an estimate that is too high and too low on the number line

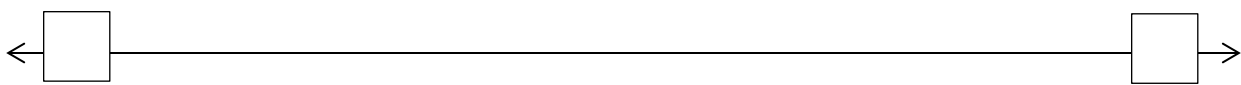

Low estimate *Place an "x" where your estimate belongs* High estimate

ACT 2

What information would you like to know or do you need to solve the MAIN question?

Record the given information (measurements, materials, etc....)

If possible, give a better estimate using this information: _____

Act 2 (cont.) Use this area for your work, tables, calculations, sketches, and final solution.

ACT 3

Georgia Department of Education
Georgia Standards of Excellence Middle School Support
GSE Grade 6 • Connections/Support Materials for Remediation

What was the result?

Which Standards for Mathematical Practice did you use?	
<input type="checkbox"/> Make sense of problems & persevere in solving them	<input type="checkbox"/> Use appropriate tools strategically.
<input type="checkbox"/> Reason abstractly & quantitatively	<input type="checkbox"/> Attend to precision.
<input type="checkbox"/> Construct viable arguments & critique the reasoning of others.	<input type="checkbox"/> Look for and make use of structure.
<input type="checkbox"/> Model with mathematics.	<input type="checkbox"/> Look for and express regularity in repeated reasoning.

CLOSING/SUMMARIZER

ACT THREE:

Have students share their solutions via a gallery walk. Have the students reflect on their solutions and the solutions they viewed. Ask the students: “Were there any strategies solutions, or arguments that stick out in your mind? Why?” Have the students write about them in their journals.

Quick Check

STANDARDS FOR MATHEMATICAL CONTENT

MFANSQ1. Students will analyze number relationships.

b. Understand a fraction a/b as a multiple of $1/b$. (MGSE4.NF.4)

MFANSQ4. Students will apply and extend previous understanding of addition, subtraction, multiplication, and division.

b. Find sums, differences, products, and quotients of all forms of rational numbers, stressing the conceptual understanding of these operations. (MGSE7.NS.1,2)

Quick Check - Formative Assessment

1. Complete the following sentence. An improper fraction b) has a value more than 1

a) has a 1 in the numerator

b) has a value more than 1

c) has a value less than 1

d) is equal to 1

2. What is a numerator? a

a) the top part of a fraction

b) the bottom part of a fraction

c) the value of a fraction

d) a number equal to 1

3. If you have $\frac{3}{8}$, how much do you need to make a whole (Hint: a whole is equal to 1)? d

a) 5

b) $\frac{3}{8}$

c) $\frac{8}{8}$

d) $\frac{5}{8}$

4. If the numerator is larger than the denominator, then the value of the fraction is c

a) equal to 1

b) less than 1

c) more than 1

d) equal to 0

5. Fill in the blank. *A fraction is equal to 1 (one) when numerator and denominator are the same*

6. a) Add the following fractions. $\frac{3}{5} + \frac{4}{5} = ?$ $7/5 = 1 \frac{2}{5}$

b) Draw a picture of your problem.

Pictures will vary, but $3/5$ and $4/5$ added together to equal 1 and $2/5$ needs to be clear

7. Fill in the blank. $\frac{5}{11} + \frac{6}{11} = \frac{11}{11} = 1$

$6/11$ is the answer

Georgia Department of Education
Georgia Standards of Excellence Middle School Support
GSE Grade 6 • Connections/Support Materials for Remediation

8. Subtract the following fractions. $\frac{5}{8} - \frac{2}{8} = ?$ Answer should be $\frac{3}{8}$

9. Add the following fractions. Give the answer as an improper fraction and a mixed numeral.

$$\frac{2}{3} + \frac{6}{3} =$$

Answer should be $\frac{8}{3}$ and $2 \frac{2}{3}$

10. Given, $\frac{4}{9} + \frac{5}{9} = \frac{9}{9} = 1$, what fraction would you add to your answer to make it equal to 2? $\frac{9}{9}$

Quick Check - Formative Assessment

1. Complete the following sentence. An improper fraction _____
a) has a 1 in the numerator b) has a value more than 1
c) has a value less than 1 d) is equal to 1

2. What is a numerator?
a) the top part of a fraction b) the bottom part of a fraction
c) the value of a fraction d) a number equal to 1

3. If you have $\frac{3}{8}$, how much do you need to make a whole (Hint: a whole is equal to 1)?
a) 5 b) $\frac{3}{8}$ c) $\frac{8}{8}$ d) $\frac{5}{8}$

4. If the numerator is larger than the denominator, then the value of the fraction is
a) equal to 1 b) less than 1 c) more than 1 d) equal to 0

5. Fill in the blank. *A fraction is equal to 1 (one) when _____.*

6. a) Add the following fractions. $\frac{3}{5} + \frac{4}{5} = ?$
b) Draw a picture of your problem.

7. Fill in the blank. $\frac{5}{11} + \quad - \quad = \frac{11}{11} = 1$

8. Subtract the following fractions. $\frac{5}{8} - \frac{2}{8} = ?$

9. Add the following fractions. Give the answer as an improper fraction and a mixed numeral.
 $\frac{2}{3} + \frac{6}{3} =$

10. Given, $\frac{4}{9} + \frac{5}{9} = \frac{9}{9} = 1$, what fraction would you add to your answer to make it equal to 2?

Birthday Cake

SUGGESTED TIME FOR THIS LESSON:

50-60 minutes

Exact timings will depend on the needs of your class.

STANDARDS FOR MATHEMATICAL CONTENT

Students will compare different representations of numbers (i.e., fractions, decimals, radicals, etc.) and perform basic operations using these different representations.

MFANSQ1. Students will analyze number relationships.

b. Understand a fraction a/b as a multiple of $1/b$. (MGSE4.NF.4)

MFANSQ4. Students will apply and extend previous understanding of addition, subtraction, multiplication, and division.

b. Find sums, differences, products, and quotients of all forms of rational numbers, stressing the conceptual understanding of these operations. (MGSE7.NS.1,2)

c. Interpret and solve contextual problems involving division of fractions by fractions. For example, how many $3/4$ -cup servings are in $2/3$ of a cup of yogurt? (MGSE6.NS.1)

d. Illustrate and explain calculations using models and line diagrams. (MGSE7.NS.1,2)

Common Misconceptions

- *Many students do not have a firm understanding of the part to whole concept. Visual representations are needed to build this foundation.*
- *Students seem to feel the need to use cross products any time they are working with fractions. While cross-products is not a method taught in the standards, many students have been exposed to this method along the way.*

STANDARDS FOR MATHEMATICAL PRACTICE

1. Make sense of problems and persevere in solving them. Students solve problems by applying and extending their understanding of multiplication and division to decimals. Students seek the meaning of a problem and look for efficient ways to solve it. They determine where to place the decimal point in calculations.

2. Reason abstractly and quantitatively. Students demonstrate abstract reasoning to connect decimal quantities to fractions, and to compare relative values of decimal numbers. Students round decimal numbers using place value concepts.

3. Construct viable arguments and critique the reasoning of others. Students construct arguments using concrete referents, such as objects, pictures, and drawings. They explain calculations and placement of the decimal point, based upon models and rules that generate patterns. They explain their thinking to others and respond to others' thinking.

4. Model with mathematics. Students use base ten blocks, drawings, number lines, and equations to represent decimal place value, multiplication and division. They determine which models are most efficient for solving problems.

5. Use appropriate tools strategically. Students select and use tools such as graph or grid paper, base ten blocks, and number lines to accurately solve multiplication and division problems with decimals.

6. Attend to precision. Students use clear and precise language, (math talk) in their discussions with others and in their own reasoning. Students use appropriate terminology when referring to decimal place value and use decimal points correctly.

7. Look for and make use of structure. Students use properties of operations as strategies to multiply and divide with decimals. Students utilize patterns in place value and powers of ten to correctly place the decimal point.

8. Look for and express regularity in repeated reasoning. Students use repeated reasoning to understand algorithms and make generalizations about patterns. Students connect place value and properties of operations to fluently multiply and divide decimals.

EVIDENCE OF LEARNING/LEARNING TARGET

By the conclusion of this lesson, students should be able to determine the fractional part of a given set and determine the whole set given the fractional part.

MATERIALS

- “Birthday Cake” student recording sheet
- Optional Manipulatives:
 - Paper plates of large circles either cut out or drawn
 - Two sided counters, base ten units, or some other small counter

ESSENTIAL QUESTIONS

- What does it mean to take a fraction portion of a whole number?
- How is multiplication of fractions similar to division of whole numbers?
- How do we determine the whole amount when given a fractional value of the whole?
- How do we determine a fractional value when given the whole number?

Grouping: Group/Partner Lesson

OPENER/ACTIVATOR

Before asking students to work on this lesson, be sure students are able to:

- Use repeated addition to add fractions with the same denominator.
- Be able to decompose fraction, for example $\frac{4}{4} = \frac{1}{2} + \frac{1}{2}$ or $\frac{1}{4} + \frac{3}{4}$.
- Have a strong understanding that the whole can be any number/size and the fractions always depend on taking a portion of this whole.



- Given 24 students in the class, how could the candy bar be divided so that everyone in the class receives an equal part? How much would each student receive?
- Give 3 expressions which are equivalent to $12 \div 12$.

WORK SESSION

BACKGROUND KNOWLEDGE

For this activity students will be asked to determine the given number of candles on each piece of birthday cake when given a total number of candles on the cake. All problems assume that the cake pieces will be equal and everyone will always receive the same number of candles. The first part of the assignment provides students with whole to part problems. In other words, the students receive the whole amount in the question but need to produce the part of the whole to determine their answer. In the second part of the lesson, students are given the number of candles on just one piece of cake or one fraction of the cake and have to then determine how many candles were on the entire cake. The second part of the assignment provides students with part to whole problems where they receive a part or fraction in the question but need to produce the whole amount to determine the answer.

Whole to Part

The four people at Tanya’s birthday will get one-quarter (one-fourth) of the cake each. Tanya puts 12 candles on the cake so that each person gets the same number of candles on their piece of cake. How many candles will each person get on their piece of cake?

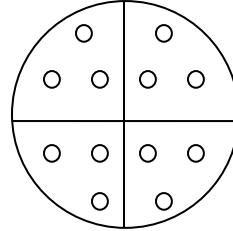

In the problem above the students need to determine the “part” when given the whole of 12 candles (i.e. 3 candles)

Part to Whole

Ricardo put enough candles on his birthday cake so that everyone would have the same number of candles. He then cut the cake into fourths. If each slice has three candles, how many candles did Ricardo put on his cake?

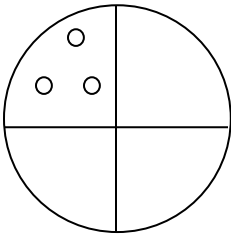

In the problem above, the students need to determine the “whole” when given only the part (i.e. $\frac{1}{4}$ of the cake had 3 candles, therefore the whole must be 12 candles). Although not always the case, these types of problems often pose a greater challenge to students.

Many of these could be completed by using simple division or multiplication without fractions at all. However, students need to understand that the / or slash in any fraction really means the division operation. By completing lessons such as these, students will begin to see a pattern and develop different strategies for multiplying and dividing denominators in order to solve problems that involve fractions.

LESSON DESCRIPTION, DEVELOPMENT, AND DISCUSSION

In this lesson, students will use a pie model to multiply a whole number by a fraction. Students will gain experience solving both part-to-whole and whole-to-part word problems that ask them to multiply a fraction by a whole number or multiply a whole number by a fraction

Teacher's Notes

Paper plates and counters should be made available for students to act out each of these problems. If paper plates are not available, a large circle drawn on an 11 x 8.5-inch paper will work just as well. Students could also color or draw their candles, or use glue and die cuts.

This lesson could be introduced by bringing in a cake and showing students how to distribute the candles in such a way that everyone receiving cake would get the same number of candles.

Lesson Directions

Students will follow directions below from the “Birthday Cake!” student recording sheet.

- Obtain a set of counters and paper plates.
- Work with a partner or small group to make a fraction cake and record it on your lesson sheet.
- Be ready to articulate your reasoning.

FORMATIVE ASSESSMENT QUESTIONS

- How do you know how many pieces of cake there are?
- Can you write an equivalent fraction for your answer? (for the example above, $\frac{1}{4} = \frac{3}{12}$)
- Are the candles evenly distributed or fairly distributed?
- In what other situations do we need to share evenly?

DIFFERENTIATION

Extension

- Once students have completed the lesson above, this lesson could be extended to use larger numbers of candles and larger fractions.
- Students could solve problems where the numerator is a number other than 1. For example, $\frac{5}{6}$ of 30.
- Students could also extend this lesson by exploring how the lesson would change if you had 2 or 3 cakes rather than just one whole cake.

Interventions

- Students may use repeated addition to solve these problems.
- Students may be given cakes already “cut” or drawn in parts to help them realize what the denominator will be.
- Initially students can start with a smaller task such as 4 candles on a cake cut into $\frac{1}{4}$ then move up gradually to 8 candles on a cake cut into $\frac{1}{4}$ and eventually 12 candles on a cake.
- For extra help with multiplying who numbers and fractions please open the hyperlink [Intervention Table](#).

TECHNOLOGY

- <http://illuminations.nctm.org/LessonDetail.aspx?ID=L342> In this lesson, students identify fractions in real-world contexts from a set of items that are not identical. It can be used as an extension of the concept.
- http://www.visualfractions.com/Identify_sets.html This site would be best utilized with a lot of guidance from the teacher. It can be used to reinforce the concept within a small group or extend understanding of the concept.
- <http://illuminations.nctm.org/LessonDetail.aspx?ID=L339> In this lesson, students identify fractions in real-world contexts from a set of items that are not identical. It can be used as an extension of the concept.

Name _____ Date _____

Birthday Cake! Part 1



- Act out the problem using circles and counters.
- Draw your answer using the circle.
- Explain your answer using words.
- Lastly, write a number sentence for each problem

1. The four people at Carla's birthday will get one-quarter (one-fourth) of the cake each. Carla puts 16 candles on the cake so that each person gets the same number of candles on their piece of cake. How many candles will each person get on their piece of cake?

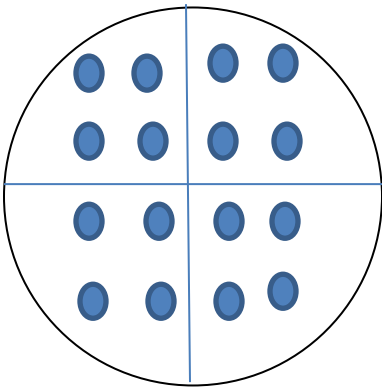

Explanation and Number Sentence

$$\frac{1}{4} \times 16 = 4 \text{ candles/section}$$

2. Three people are at Emmanuel's birthday party. Emmanuel puts 21 candles on the cake and cuts it into thirds so that each person gets the same number of candles on their piece of cake. How many candles will each person get on their piece of cake? (*The picture may not look to scale; the pieces should be thought of as the same size.*)

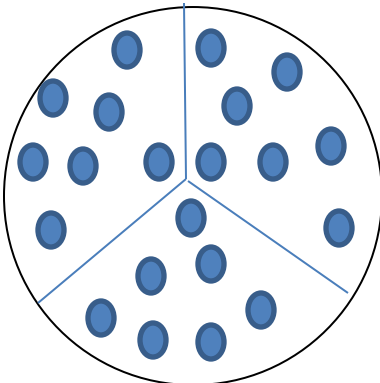

Explanation and Number Sentence

$$\frac{1}{3} \times 21 = 7 \text{ candles/section}$$

3. At the party, the cake is cut into quarters (fourths). Twelve candles are put on the cake. Greedy Greg eats three-quarters of the cake. How many candles does he get?

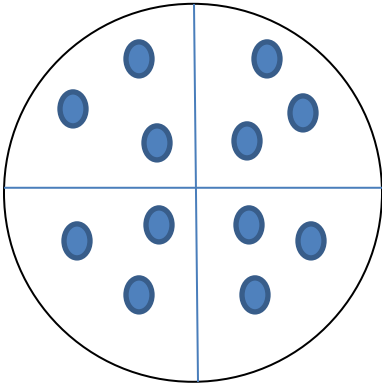

Explanation and Number Sentence

$\frac{1}{4} \times 12 = 3 \text{ candles/section}$

Name _____ Date _____

Birthday Cake! Part 1



- Act out the problem using circles and counters.
- Draw your answer using the circle.
- Explain your answer using words.
- Lastly, write a number sentence for each problem

1. The four people at Carla's birthday will get one-quarter (one-fourth) of the cake each. Carla puts 16 candles on the cake so that each person gets the same number of candles on their piece of cake. How many candles will each person get on their piece of cake?

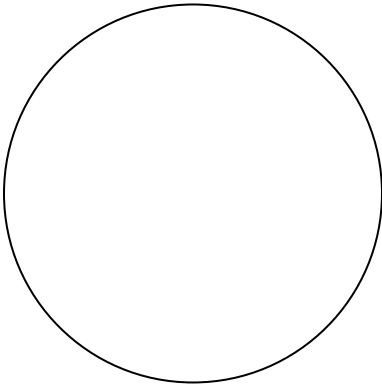

Explanation and Number Sentence

2. Three people are at Emmanuel's birthday party. Emmanuel puts 21 candles on the cake and cuts it into thirds so that each person gets the same number of candles on their piece of cake. How many candles will each person get on their piece of cake?

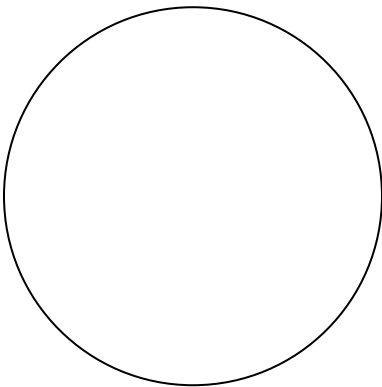

Explanation and Number Sentence

3. At the party, the cake is cut into quarters (fourths). Twelve candles are put on the cake. Greedy Greg eats three-quarters of the cake. How many candles does he get?

Explanation and Number Sentence

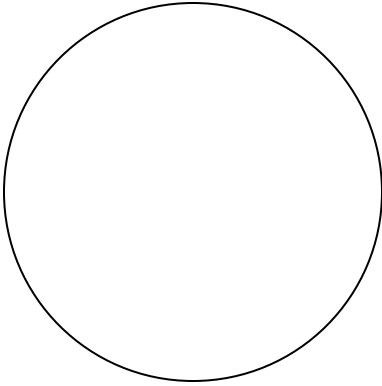

Name _____ Date _____

Birthday Cake! Part 2



- Act out the problem using circles and counters.
- Draw your answer using the circle.
- Explain your answer using words.
- Lastly, write a number sentence for each problem.

1. Stan put enough candles on his birthday cake so that everyone would have the same number of candles. He then cut the cake into fourths. If each slice has six candles, how many candles did Stan put on his cake?

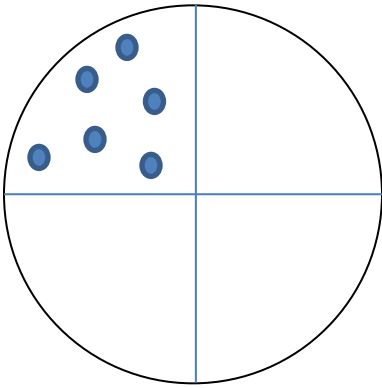

Explanation and Number Sentence

$\frac{1}{4}$ of the whole cake had 6 candles; therefore, the whole cake had 24 candles.

$$6 \text{ candles} \times 4 \text{ sections} = 24 \text{ candles on the whole cake}$$

2. Pedro put enough candles on his birthday cake so that everyone would have the same number of candles. After cutting himself a large slice he noticed that two-thirds of the cake has eight candles on it. How many candles are on the whole cake?

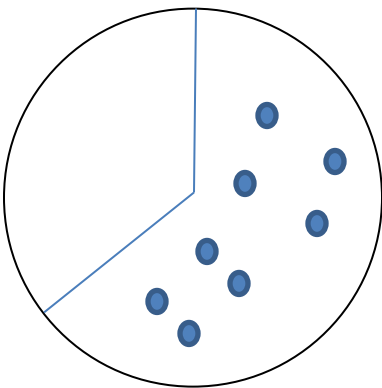

Explanation and Number Sentence

$\frac{2}{3}$ of the whole cake had 8 candles; therefore, $\frac{1}{3}$ of the whole cake had 4 candles. Since $\frac{2}{3} + \frac{1}{3} = 1$ whole cake, the whole cake had $8 + 4 = 12$ candles.

3. Priya and her father made a cake for her birthday and put enough candles on it so that everyone would have the same number of candles. Priya's father cut the cake into fourths and gave Priya the first slice. He then noticed that the three-fourths of the cake that was left had twelve candles on it. How many candles were on the whole cake?

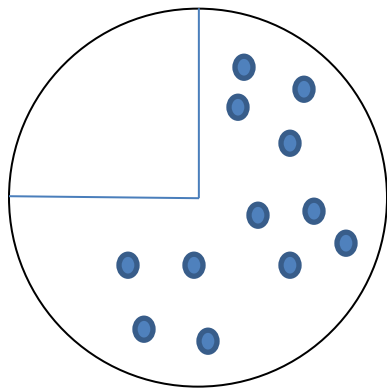

Explanation and Number Sentence

If $\frac{3}{4}$ of the cake had 12 candles then $\frac{1}{4}$ of the cake has 4 candles. Since $\frac{3}{4} + \frac{1}{4} = 1$ whole cake, 12 candles (from the $\frac{3}{4}$ section of the cake) + 4 candles (from the $\frac{1}{4}$ section of the cake) = 16 candles on the whole cake

Name _____ Date _____

Birthday Cake! Part 2



- Act out the problem using circles and counters.
- Draw your answer using the circle.
- Explain your answer using words.
- Lastly, write a number sentence for each problem.

1. Stan put enough candles on his birthday cake so that everyone would have the same number of candles. He then cut the cake into fourths. If each slice has six candles, how many candles did Stan put on his cake?

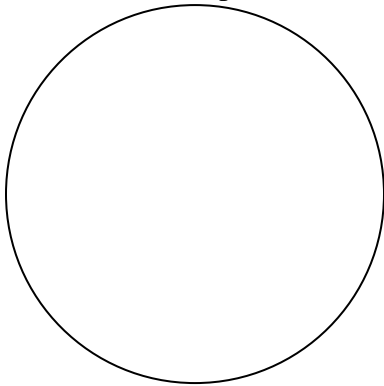

Explanation and Number Sentence

2. Pedro put enough candles on his birthday cake so that everyone would have the same number of candles. After cutting himself a large slice he noticed that two-thirds of the cake has eight candles on it. How many candles are on the whole cake?

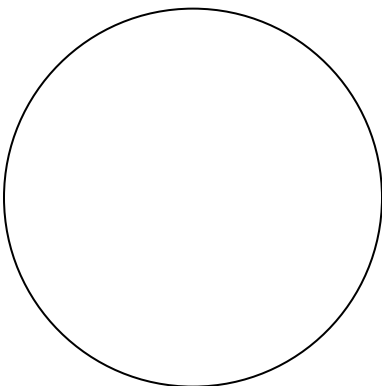

Explanation and Number Sentence

Georgia Department of Education
Georgia Standards of Excellence Middle School Support
GSE Grade 6 • Connections/Support Materials for Remediation

3. Priya and her father made a cake for her birthday and put enough candles on it so that everyone would have the same number of candles. Priya's father cut the cake into fourths and gave Priya the first slice. He then noticed that the three-fourths of the cake that was left had twelve candles on it. How many candles were on the whole cake?

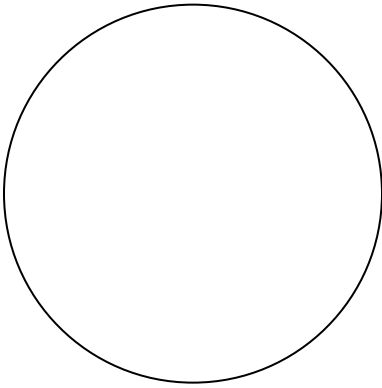

Explanation and Number Sentence

CLOSING/SUMMARIZER

TE: TICKET OUT THE DOOR – SOLUTIONS

The cake below was cut into thirds. How many candles were on the whole cake?

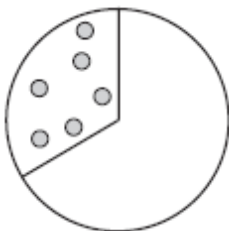

6 candles x 3 sections = 18 total candles

The cake below was cut into fourths. How many candles were on the whole cake?

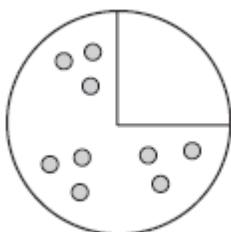

3 candles x 4 sections = 12 total candles

The cake below was cut into fifths. How many candles were on the whole cake?

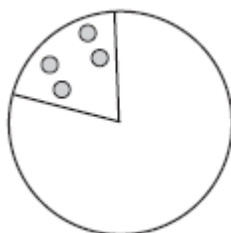

4 candles x 5 sections = 20 total candles

Student Edition: TICKET OUT THE DOOR

The cake below was cut into thirds. How many candles were on the whole cake?

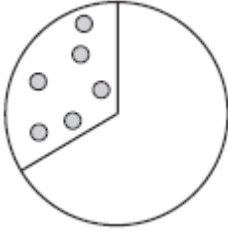

The cake below was cut into fourths. How many candles were on the whole cake?

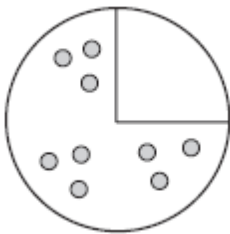

The cake below was cut into fifths. How many candles were on the whole cake?

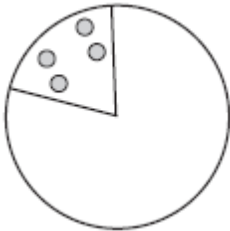

Fraction Clues

SUGGESTED TIME FOR THIS LESSON:

60-90 minutes

Exact timings will depend on the needs of your class.

STANDARDS FOR MATHEMATICAL CONTENT

Students will compare different representations of numbers (i.e., fractions, decimals, radicals, etc.) and perform basic operations using these different representations.

MFANSQ1. Students will analyze number relationships.

b. Understand a fraction a/b as a multiple of $1/b$. (MGSE4.NF.4)

MFANSQ4. Students will apply and extend previous understanding of addition, subtraction, multiplication, and division.

b. Find sums, differences, products, and quotients of all forms of rational numbers, stressing the conceptual understanding of these operations. (MGSE7.NS.1,2)

c. Interpret and solve contextual problems involving division of fractions by fractions. For example, how many $3/4$ -cup servings are in $2/3$ of a cup of yogurt? (MGSE6.NS.1)

d. Illustrate and explain calculations using models and line diagrams. (MGSE7.NS.1,2)

Common Misconceptions

- *Many students do not have a firm understanding of the part to whole concept. Visual representations are needed to build this foundation.*
- *Students seem to feel the need to use cross products any time they are working with fractions. While cross-products is not a method taught in the standards, many students have been exposed to it along the way.*

STANDARDS FOR MATHEMATICAL PRACTICE

1. Make sense of problems and persevere in solving them. Students solve problems by applying and extending their understanding of multiplication and division to decimals. Students seek the meaning of a problem and look for efficient ways to solve it. They determine where to place the decimal point in calculations.

2. Reason abstractly and quantitatively. Students demonstrate abstract reasoning to connect decimal quantities to fractions, and to compare relative values of decimal numbers. Students round decimal numbers using place value concepts.

3. Construct viable arguments and critique the reasoning of others. Students construct arguments using concrete referents, such as objects, pictures, and drawings. They explain calculations and placement of the decimal point, based upon models and rules that generate patterns. They explain their thinking to others and respond to others' thinking.

4. Model with mathematics. Students use base ten blocks, drawings, number lines, and equations to represent decimal place value, multiplication and division. They determine which models are most efficient for solving problems.

5. Use appropriate tools strategically. Students select and use tools such as graph or grid paper, base ten blocks, and number lines to accurately solve multiplication and division problems with decimals.

6. Attend to precision. Students use clear and precise language, (math talk) in their discussions with others and in their own reasoning. Students use appropriate terminology when referring to decimal place value and use decimal points correctly.

7. Look for and make use of structure. Students use properties of operations as strategies to multiply and divide with decimals. Students utilize patterns in place value and powers of ten to correctly place the decimal point.

8. Look for and express regularity in repeated reasoning. Students use repeated reasoning to understand algorithms and make generalizations about patterns. Students connect place value and properties of operations to fluently multiply and divide decimals.

EVIDENCE OF LEARNING/LEARNING TARGET

By the conclusion of this lesson, students should be able to:

- Determine the fractional part of a given set.
- Find the whole set given a fractional part.
- Find equivalent fractions.

MATERIALS

- Colored Tiles
- Fraction Clues recording sheet
- Colored pencils

ESSENTIAL QUESTIONS

- How can a fraction represent parts of a set?
- How can you represent fractions in different ways?
- How can you find equivalent fractions?
- How can you multiply a set by a fraction?

BACKGROUND INFORMATION

This activity is valuable because students start to realize that a different number of tiles in a different fraction bar can still be represented by the same fraction. For example

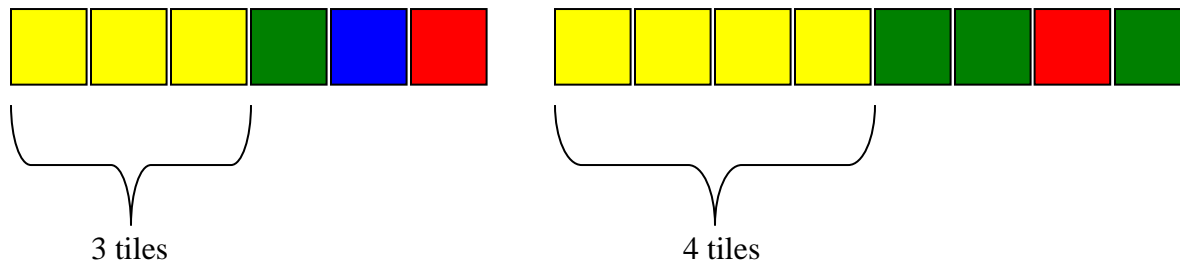

In the first bar, three yellow tiles represent $\frac{1}{2}$ and in the second bar four tiles represent $\frac{1}{2}$. Students will gain further understanding that the number of tiles being used (numerator) is always dependent on its relationship to the total number of tiles (denominator).

Before asking students to work on this lesson, be sure students are able to:

- identify the number of equal pieces needed to cover one whole as the denominator
- show equivalent fractions with an area model
- record on the student sheet equivalent fractions or fraction sets (either by coloring or gluing die cut squares)
- write an equation which shows the clues and verify their answer.

Grouping: Partner

OPENING/ACTIVATOR

To introduce this activity display these two fraction bars made from Color Tiles.



Ask students to find out what portion of the whole a tile in the first bar represents and what portion of the whole a tile in the second bar represents. Students should be able to determine that each tile in the first bar represents $\frac{1}{4}$ of the whole and each tile in the second bar represents $\frac{1}{6}$ of the whole.

Ask students to explain what fractional part each color represents in each fraction bar. Give the following set of fraction clues that describe one of the fraction bars. Stop after each clue and ask students which fraction bar is the solution and how they know.

- The fraction bar is one-half green
- The fraction bar is one-third red
- The fraction is one-sixth blue

Many students will not need all three clues to determine the solution however, they should be comfortable arguing and verifying their answers. They may need all three clues to conclude that the solution is the second bar.

WORK SESSION

Lesson Directions (*Note: Answers will vary.*)

Students will follow directions below from the Fraction Clues activity sheet.

- Obtain a set of colored tiles.
- Work with a partner to make a fraction bar and record it on their activity sheet.
- Write at least 3 clues that describe your fraction bar
- Exchange only your clues with another group
- Represent your answer with a number sentence (for example: if you have 10 tiles and $\frac{1}{2}$ are red, then write the number sentence $10 \times \frac{1}{2} = 5$ which is 5 tiles)
- Attempt to build another group's fraction bar as they attempt to build yours.
- Discuss results with each other.

Extension

- Once students have completed the lesson above, the lesson can be extended to have two pairs of students combine their fraction bars to make a larger fraction bar, then continue the activity writing clues for another group to solve.
- Students could also be encouraged to work with larger fraction bars as well as write more clues for determining those fraction bars. Most color tiles only have red, blue, green and yellow tiles; so, the activity will never have more than four fractions to represent.
- Often the clue with the largest denominator tells you how many tiles can be used. However, students could be challenged to use only 2 clues and therefore force them into situations where they need to find common denominators. For example, my fractions are $\frac{1}{4}$ red and $\frac{1}{3}$ green. They will then need to build several bars that have 12 or 24 tiles.

Intervention

- If necessary students could begin this activity with a smaller set, such as using only four tiles.
- If students are struggling, they could attempt with activity with only three colors instead of using all four colored tiles.

TECHNOLOGY

- <http://illuminations.nctm.org/LessonDetail.aspx?ID=L342> helps students identify fractions in real-world contexts from a set of items that are not identical. It can be used as an extension of the concept.
- http://www.visualfractions.com/Identify_sets.html would be best utilized with a lot of guidance from the teacher. It can be used to reinforce the concept within a small group or extend understanding of the concept.
- <http://illuminations.nctm.org/LessonDetail.aspx?ID=L339> assists students in identifying fractions in real-world contexts from a set of items that are not identical. It can be used as an extension of the concept.

Name _____ Date _____

Fraction Clues
(Part 1)



Make a Color Tile fraction bar and then write a set of clues so that someone else could build it.

- Work with a partner. Choose 6 Color Tiles and arrange them in any way to form a fraction bar.
- Decide what fractional part of the whole bar is represented by each color you used. For example:

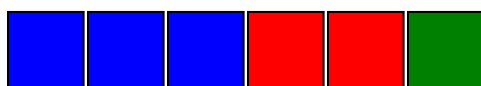

Blue: $\frac{3}{6}$ or $\frac{1}{2}$

Red: $\frac{2}{6}$ or $\frac{1}{3}$

Green: $\frac{1}{6}$

- Record your fraction bar on grid paper. Beneath the grid paper, write several clues that describe the fractional parts of your bar. For example: *My bar is _____ blue.*
- Exchange lists with another pair. Be careful not to peek at the back of the list! Follow the clues to try to build the other pair's fraction bar.
- Represent your answer with a number sentences (for example: if you have 10 tiles and $\frac{1}{2}$ are red, then write the following: $\text{Half of } 10 = 10 \times \frac{1}{2} = 5 \text{ tiles}$)
- When you have finished making the fraction bar, turn the list of clues over and compare what you built to the recording.
- Discuss your results with the other pair.

Georgia Department of Education
Georgia Standards of Excellence Middle School Support
GSE Grade 6 • Connections/Support Materials for Remediation

Clue 1: _____

Clue 2: _____

Clue 3: _____

Clue 4: _____

Georgia Department of Education
Georgia Standards of Excellence Middle School Support
GSE Grade 6 • Connections/Support Materials for Remediation

- Work with a partner. Choose 8 color tiles and arrange them in any way to form a fraction bar.
- Decide what fractional part of the whole bar is represented by each color you used. For example:



Blue: $\frac{3}{8}$

Red: $\frac{2}{8}$ or $\frac{1}{4}$

Green: $\frac{3}{8}$

- Record your fraction bar on grid paper. Beneath the grid paper, write several clues that describe the fractional parts of your bar. For example: *My bar is _____ blue.*
- Exchange lists with another pair. Be careful not to peek at the back of the list! Follow the clues to try to build the other pair's fraction bar.
- Represent your answer with a number sentence (for example: if you have 10 tiles and $\frac{1}{2}$ are red then write the number sentence $10 \div 2 = 5$ tiles)
- When you have finished making the fraction bar, turn the list of clues over and compare what you built to the recording.
- Discuss your results with the other pair.

Georgia Department of Education
Georgia Standards of Excellence Middle School Support
GSE Grade 6 • Connections/Support Materials for Remediation

Clue 1: _____

Clue 2: _____

Clue 3: _____

Clue 4: _____

Georgia Department of Education
Georgia Standards of Excellence Middle School Support
GSE Grade 6 • Connections/Support Materials for Remediation

- Work with a partner. Choose 12 Color Tiles and arrange them in any way to form a fraction bar.
- Decide what fractional part of the whole bar is represented by each color you used. For example:



Blue: $\frac{4}{12}$ or $\frac{1}{3}$

Red: $\frac{2}{12}$ or $\frac{1}{6}$

Green: $\frac{6}{12}$ or $\frac{1}{2}$

- Record your fraction bar on grid paper. Beneath the grid paper, write several clues that describe the fractional parts of your bar. For example: *My bar is _____ blue.*
- Exchange lists with another pair. Be careful not to peek at the back of the list! Follow the clues to try to build the other pair's fraction bar.
- Represent your answer with a number sentences (for example: if you have 10 tiles and $\frac{1}{2}$ are red then write the number sentence $10 \div 2 = 5$ tiles)
- When you have finished making the fraction bar, turn the list of clues over and compare what you built to the recording.
- Discuss your results with the other pair.

CLOSING/SUMMARIZER (*Note: Answers will vary.*)

Name _____ Date _____

Fraction Clues
(Part 2)



Make a Color Tile fraction bar and then write a set of clues so that someone else could build it

- Work with a partner. Choose any number of Color Tiles and arrange them in any way to form a fraction bar.
- Decide what fractional part of the whole bar is represented by each color you used. For example:



Blue: $\frac{3}{6}$ or $\frac{1}{2}$

Red: $\frac{2}{6}$ or $\frac{1}{3}$

Green: $\frac{1}{6}$

- Record your fraction bar on grid paper. Beneath the grid paper, write several clues that describe the fractional parts of your bar. For example: *My bar is _____ blue.*
- Exchange lists with another pair. Be careful not to peek at the back of the list! Follow the clues to try to build the other pair's fraction bar.
- Represent your answer with a number sentences (for example: if you have 10 tiles and $\frac{1}{2}$ are red then write the number sentence $10 \times \frac{1}{2} = 10 \div 2 = 5$ tiles)
- When you have finished making the fraction bar, turn the list of clues over and compare what you built to the recording.
- Discuss your results with the other pair.

Georgia Department of Education
Georgia Standards of Excellence Middle School Support
GSE Grade 6 • Connections/Support Materials for Remediation

Clue 1: _____

Clue 2: _____

Clue 3: _____

Clue 4: _____

Multiplying Fractions

SUGGESTED TIME FOR THIS LESSON:

60-90 minutes

Exact timings will depend on the needs of your class.

STANDARDS FOR MATHEMATICAL CONTENT

Students will compare different representations of numbers (i.e., fractions, decimals, radicals, etc.) and perform basic operations using these different representations.

MFANSQ1. Students will analyze number relationships.

b. Understand a fraction a/b as a multiple of $1/b$. (MGSE4.NF.4)

MFANSQ4. Students will apply and extend previous understanding of addition, subtraction, multiplication, and division.

b. Find sums, differences, products, and quotients of all forms of rational numbers, stressing the conceptual understanding of these operations. (MGSE7.NS.1,2)

c. Interpret and solve contextual problems involving division of fractions by fractions. For example, how many $3/4$ -cup servings are in $2/3$ of a cup of yogurt? (MGSE6.NS.1)

d. Illustrate and explain calculations using models and line diagrams. (MGSE7.NS.1,2)

Common Misconceptions:

Students often have the mindset that the operation of multiplication produces a larger product and the operation of division produces a smaller quotient. Students should develop an understanding that when a number is multiplied by a number less than 1, the product is less than the original number, and when a number is divided by a decimal number less than 1, the quotient will be greater than the dividend. This is important, yet often difficult for students to understand because it is counterintuitive based on students' previous experiences with multiplication and division.

STANDARDS FOR MATHEMATICAL PRACTICE

- 1. Make sense of problems and persevere in solving them.** Students solve problems by applying and extending their understanding of multiplication and division to decimals. Students seek the meaning of a problem and look for efficient ways to solve it. They determine where to place the decimal point in calculations.
- 2. Reason abstractly and quantitatively.** Students demonstrate abstract reasoning to connect decimal quantities to fractions, and to compare relative values of decimal numbers. Students round decimal numbers using place value concepts.
- 3. Construct viable arguments and critique the reasoning of others.** Students construct arguments using concrete referents, such as objects, pictures, and drawings. They explain calculations and placement of the decimal point, based upon models and rules that generate patterns. They explain their thinking to others and respond to others' thinking.
- 4. Model with mathematics.** Students use base ten blocks, drawings, number lines, and equations to represent decimal place value, multiplication and division. They determine which models are most efficient for solving problems.
- 5. Use appropriate tools strategically.** Students select and use tools such as graph or grid paper, base ten blocks, and number lines to accurately solve multiplication and division problems with decimals.
- 6. Attend to precision.** Students use clear and precise language, (math talk) in their discussions with others and in their own reasoning. Students use appropriate terminology when referring to decimal place value and use decimal points correctly.
- 7. Look for and make use of structure.** Students use properties of operations as strategies to multiply and divide with decimals. Students utilize patterns in place value and powers of ten to correctly place the decimal point.
- 8. Look for and express regularity in repeated reasoning.** Students use repeated reasoning to understand algorithms and make generalizations about patterns. Students connect place value and properties of operations to fluently multiply and divide decimals.

EVIDENCE OF LEARNING/LEARNING TARGET

By the conclusion of this lesson, students should be able to:
Represent multiplication of fractions using an area model.
Determine various fractions of whole numbers.

MATERIALS

- Colored pencils
- Area Model recording sheet
- “How many CC’s?” recording sheet

ESSENTIAL QUESTIONS

- What strategies can be used for finding products when multiplying a whole number by a fraction?
- How can you model the multiplication of a whole number by a fraction?
- How do you multiply a fraction by a whole number?

Grouping: Individual/Partner

OPENER/ACTIVATOR

Lesson Directions

Have students follow the directions on the area model recording sheet. Use the square below to draw an area model to represent the following multiplication problems. Use your area model to help you compute the answer to each problem.

SOLUTIONS:

Draw an area model to represent each of the following operations. Use your area model to help you compute the answer to each problem.

$$6 \cdot \frac{2}{3} \text{ Answers will vary.}$$

Possible Solution

A possible solution for $6 \cdot \frac{2}{3}$ is below. This model shows six rectangles with each having $\frac{2}{3}$ of their area shaded. The results show $\frac{12}{3}$ shaded which is equivalent to 4 whole rectangles.

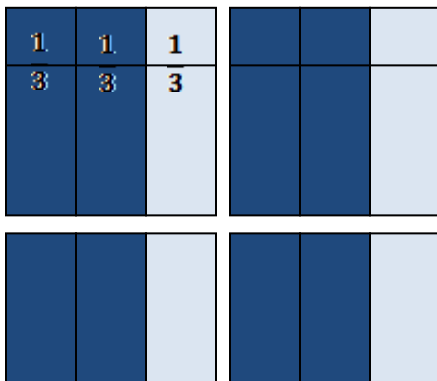

Name _____ Date _____

Area Models: Multiplication

Use the squares below to draw an area model to represent the following multiplication problems.
Use your area model to help you compute the answer to each problem.

$$6 \cdot \frac{2}{3}$$

Explanation:

Georgia Department of Education
Georgia Standards of Excellence Middle School Support
GSE Grade 6 • Connections/Support Materials for Remediation

$$8 \cdot \frac{3}{4}$$

Explanation:

$$6 \cdot \frac{2}{5}$$

Explanation:

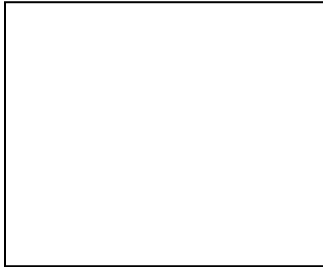

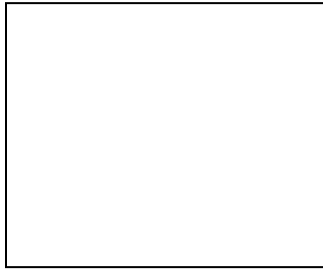
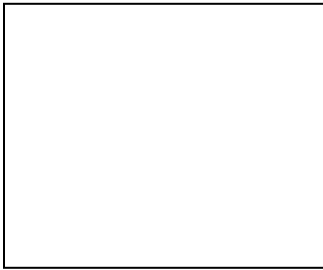

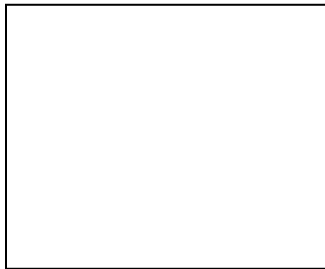

Use the squares below to draw an area model to represent the following operations. Use your area model to help you compute the answer to each problem. What happens if you switch the equation around to read $\frac{1}{2}$ times 8?

$$8 \cdot \frac{1}{2}$$

Explanation:

LESSON DESCRIPTION, DEVELOPMENT AND DISCUSSION

To complete this lesson correctly, students must understand that the amount of drainage fluid and Albumin are equivalent for each reading. Clues are provided within the table to help the students determine the cc of fluid for each. On one occasion, students use the amount of Albumin to determine the drainage fluid.

You can explain to the students “cc” are the cubic centimeters commonly used to measure fluids in the medical field. It is not necessary to attempt to convert cc to another unit of measure.

LESSON SOLUTIONS:

Registered Nurse Molly has a patient with a drainage tube in her abdomen. The tube was inserted after a recent surgery. The volume measured in the tube has to be replaced by a blood product called albumin through an IV line. Nurse Molly checks the drainage every 6 hours. The chart below shows the amount of fluid measured in the drainage tube at the checked times. Help Nurse Molly determine how much Albumin to give the patient after each checkpoint.

Encourage the students to think of money.

Time	Drainage Fluid	Albumin
6:00am	100cc	<i>Whatever comes out must be replaced 100cc</i>
12 noon	$\frac{3}{4}$ of the volume at 6am	$\frac{3}{4} \times 100 = 75cc$
6:00pm	<i>If 75 cc of Albumin was added the patient must have lost 75cc</i>	75cc
12 midnight	$\frac{2}{3}$ of the volume at 6pm	$\frac{2}{3} \times 75 = 50cc$ <i>(Think of money – there are 3 quarters in 75 cents then double it.)</i>
6:00am	$\frac{4}{8}$ of 100cc	$\frac{4}{8} \times 100 =$ *See Note Below $\frac{1}{2} \times 100 = 50cc$
12 noon	<i>If 25cc of Albumin was added the patient must have lost 25cc</i>	$\frac{1}{2}$ of 50cc = 25cc

NOTE: *Students may run into difficulty when trying to determine $\frac{4}{8}$ of 100cc. Allow students to struggle, which will provide an opportunity to apply understanding of equivalent fractions. An easy equivalent would be $\frac{1}{2}$. Again, allow students to discover this through struggle.*

DIFFERENTIATION

Extension

- The Albumin is administered from a syringe containing 100cc of the fluid using an automatic pump. If the nurse sets the pump for 30 minutes, the fluid will dispense 100cc over the course of the 30 minutes. If the nurse sets it for 15 minutes, how many cc of Albumin will be dispensed? How much time is needed to dispense 25cc? 75cc?

Intervention

- Have students determine the fraction of drainage fluid using unit fractions first. For example, $\frac{1}{4}$ of 6am before figuring $\frac{3}{4}$ of 6am.
- For extra help with multiplying fractions, please open the hyperlink [Intervention Table](#).

TECHNOLOGY

- <http://illuminations.nctm.org/LessonDetail.aspx?ID=U123> This four-part lesson can be used for additional practice or to extend understanding of the concepts.
- <http://illuminations.nctm.org/LessonDetail.aspx?ID=L341> This lesson reinforces fractional parts. It can be used to extend understanding of the concept.

Georgia Department of Education
Georgia Standards of Excellence Middle School Support
GSE Grade 6 • Connections/Support Materials for Remediation

Name: _____

Date: _____

How Many CCs?

Registered Nurse Molly has a patient with a drainage tube in her abdomen. The tube was inserted after a recent surgery. The volume measured in the tube has to be replaced by a blood product called Albumin through an iv line. Nurse Molly checks the drainage every 6 hours. The chart below shows the amount of fluid measured in the drainage tube at the checked times. Help Nurse Molly determine how much Albumin to give the patient after each checkpoint.

Time	Drainage Fluid	Albumin
6:00am	100cc	
12 noon	$\frac{3}{4}$ of the volume at 6am	
6:00pm		75cc
12 midnight	$\frac{2}{3}$ of the volume at 6pm	
6:00am	$\frac{4}{8}$ of 100cc	
12 noon		$\frac{1}{2}$ of 50cc =

CLOSING/SUMMARIZER

Possible Ticket Out the Door Question: (This is a 2-part question.)

Lanny rode his bike to school which was $\frac{1}{3}$ of a mile away. He completed this trip 4 times a day. What is the total distance the Lanny rode? Draw a picture to represent your thinking.

Abi is preparing for a $\frac{1}{2}$ marathon. She runs $4\frac{2}{3}$ of a mile every day after school. Who travels the most distance a day? Create a model of your thinking.

SOLUTION:

Distance ridden by Lanny		
Distance ridden by Lanny		
Distance ridden by Lanny		
Distance ridden by Lanny		

From the model above, Lanny rode $\frac{1}{3}$ of a mile 4 times which is $\frac{4}{3}$ or $1\frac{1}{3}$ miles.

Abi rode $4\frac{2}{3}$ miles. See representation below

If you remove Lanny's $1\frac{1}{3}$ miles (noted by the x in the boxes), you will find that Abi rode $3\frac{1}{3}$ miles more.

X	X	X
X		

Other possible questions can be found at:

<http://bit.ly/1Qn8Yih> lesson 7

Birthday Cookout

SUGGESTED TIME FOR THIS LESSON:

50-60 minutes

Exact timings will depend on the needs of your class.

STANDARDS FOR MATHEMATICAL CONTENT

Students will compare different representations of numbers (i.e., fractions, decimals, radicals, etc.) and perform basic operations using these different representations.

MFANSQ1. Students will analyze number relationships.

b. Understand a fraction a/b as a multiple of $1/b$. (MGSE4.NF.4)

MFANSQ4. Students will apply and extend previous understanding of addition, subtraction, multiplication, and division.

b. Find sums, differences, products, and quotients of all forms of rational numbers, stressing the conceptual understanding of these operations. (MGSE7.NS.1,2)

c. Interpret and solve contextual problems involving division of fractions by fractions.

For example, how many $3/4$ -cup servings are in $2/3$ of a cup of yogurt? (MGSE6.NS.1)

d. Illustrate and explain calculations using models and line diagrams. (MGSE7.NS.1,2)

STANDARDS FOR MATHEMATICAL PRACTICE

1. Make sense of problems and persevere in solving them. Students solve problems by applying and extending their understanding of multiplication and division to decimals. Students seek the meaning of a problem and look for efficient ways to solve it. They determine where to place the decimal point in calculations.

2. Reason abstractly and quantitatively. Students demonstrate abstract reasoning to connect decimal quantities to fractions, and to compare relative values of decimal numbers. Students round decimal numbers using place value concepts.

3. Construct viable arguments and critique the reasoning of others. Students construct arguments using concrete referents, such as objects, pictures, and drawings. They explain calculations and placement of the decimal point, based upon models and rules that generate patterns. They explain their thinking to others and respond to others' thinking.

4. Model with mathematics. Students use base ten blocks, drawings, number lines, and equations to represent decimal place value, multiplication and division. They determine which models are most efficient for solving problems.

5. Use appropriate tools strategically. Students select and use tools such as graph or grid paper, base ten blocks, and number lines to accurately solve multiplication and division problems with decimals.

6. Attend to precision. Students use clear and precise language, (math talk) in their discussions with others and in their own reasoning. Students use appropriate terminology when referring to decimal place value and use decimal points correctly.

7. Look for and make use of structure. Students use properties of operations as strategies to multiply and divide with decimals. Students utilize patterns in place value and powers of ten to correctly place the decimal point.

8. Look for and express regularity in repeated reasoning. Students use repeated reasoning to understand algorithms and make generalizations about patterns. Students connect place value and properties of operations to fluently multiply and divide decimals.

EVIDENCE OF LEARNING/LEARNING TARGET

By the conclusion of this lesson, students should be able to solve word problems that involve the multiplication of a whole number and a fraction.

MATERIALS

- “Birthday Cookout” recording sheet

ESSENTIAL QUESTIONS

- How can we use fractions to help us solve problems?
- How can we model answers to fraction problems?
- How can we write equations to represent our answers when solving word problems?

Grouping: Individual/Partner

OPENER/ACTIVATOR:

It is a hot day in Atlanta, GA. There are not many people at Six Flags. The Batman rollercoaster is only $\frac{2}{3}$ full. It ran 4 times at that capacity. Circle the expressions that model this scenario.

$4 - \frac{2}{3}$ $\frac{2}{3} + 4$

$\frac{2}{3} + \frac{2}{3} + \frac{2}{3} + \frac{2}{3}$ $\frac{2}{3} \times 4$

$\frac{1}{3} + \frac{1}{3} + \frac{1}{3} + \frac{1}{3} + \frac{1}{3} + \frac{1}{3} + \frac{1}{3} + \frac{1}{3}$

Student Edition:

It is a hot day in Atlanta, GA. There are not many people at Six Flags. The Batman rollercoaster coaster is only $\frac{2}{3}$ full. It ran 4 times at that capacity. Circle the expressions you could use to find how many full loads that would equal.

$$4 - \frac{2}{3}$$

$$\frac{2}{3} + 4$$

$$\frac{2}{3} + \frac{2}{3} + \frac{2}{3} + \frac{2}{3}$$

$$\frac{2}{3} \times 4$$

$$\frac{1}{3} + \frac{1}{3} + \frac{1}{3} + \frac{1}{3} + \frac{1}{3} + \frac{1}{3} + \frac{1}{3} + \frac{1}{3}$$

Additional problems can be found at: <http://bit.ly/1Qn8Yih>

WORK SESSION

LESSON DESCRIPTION, DEVELOPMENT AND DISCUSSION

This lesson asks students to use problem solving strategies and their knowledge of fractions to solve a real-world problem involving food for a birthday party.

Comments

The setting of this lesson is likely a familiar one for students. You may want to begin with a discussion of how math is used when planning a birthday party. The discussion may include a wide range of mathematical ideas such as number of invitations, amount of food, and the amount of money needed to purchase food.

Solutions are given below:

- How many people asked for chicken? ($\frac{1}{5}$ of 10 is 2)
- How many people asked for steak? ($\frac{1}{4}$ of 40 is 10)
- How many asked for hot-dogs? ($\frac{1}{2}$ of 80 is 40)

Lesson Directions

Have students follow the directions on the “Birthday Cookout” student recording sheet.

BACKGROUND KNOWLEDGE and SOLUTION

You may want to review problem-solving strategies with your students as they begin work on this lesson. Strategies such as making a table and working backward are two approaches to this lesson. Another suggestion for solving fraction word problems such as this is to utilize the Singapore Math strategy of drawing bars that are proportionate to the values in the problem. For example, we know that 80 people ordered hamburgers so we can draw a large bar to represent the hamburgers. We can then draw a bar $\frac{1}{2}$ the size of our “hamburger” bar to represent the number of people that want hotdogs. Next, we can draw a bar that is $\frac{1}{4}$ the size of our “hot dog” bar to represent the number of people that want steak. Finally, we can draw a bar $\frac{1}{5}$ the size of our “steak” bar to represent the number of people that want chicken.

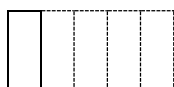

Chicken (2)

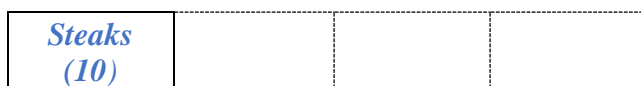

*Steaks
(10)*

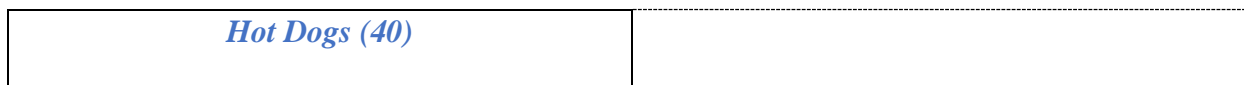

Hot Dogs (40)

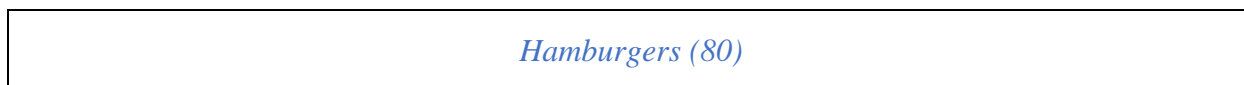

Hamburgers (80)

DIFFERENTIATION

Extension

- Have students research and determine the cost of the items the chef needs.
- Have students create their own menu and create a new problem involving fractions.
- Have students determine the percentage of guests who chose each menu item.
- Students could explore this problem with larger numbers such as 320 hamburgers and then look for patterns.
- Students could be given different information to begin with other than the number of hamburgers. How would the problem change if we only knew that 40 people asked for steak?

Intervention

- Use smaller numbers, for example instead of 80 hamburgers, use 40 hamburgers.
 - How many people asked for chicken? ($\frac{1}{5}$ of 5 is 1)
 - How many people asked for steak? ($\frac{1}{4}$ of 20 is 5)
 - How many asked for hot-dogs? ($\frac{1}{2}$ of 40 is 20)
- These lessons can always be physically performed with fraction tiles for the more kinesthetic learners. Many fraction bars are labeled and students can turn them over to assign them the value of the hamburgers, hot dogs, etc.

TECHNOLOGY

- <http://illuminations.nctm.org/LessonDetail.aspx?ID=L342> In this lesson, students identify fractions in real-world contexts from a set of items that are not identical. It can be used as an extension of the concept.
- http://www.visualfractions.com/Identify_sets.html This site would be best utilized with a lot of guidance from the teacher. It can be used to reinforce the concept within a small group or extend understanding of the concept.
- <http://illuminations.nctm.org/LessonDetail.aspx?ID=L339> In this lesson, students identify fractions in real-world contexts from a set of items that are not identical. It can be used as an extension of the concept.

Name _____

Date _____

Birthday Cookout

Bob turned 60 this year! His family celebrated by having a cookout. Marcy took orders and found one fifth as many people wanted chicken as wanted steaks, one fourth as many people wanted steaks as wanted hot dogs, and one half as many people wanted hot dogs as wanted hamburgers. She gave her son-in-law, the chef, an order for 80 hamburgers.



The chef needs more information. He has to know:

- How many people asked for chicken?
- How many people asked for steak?
- How many asked for hot-dogs?

Use words, pictures and numbers to tell the chef what he needs to know. Be prepared to share!

CLOSING/SUMMARIZER

Share your results of “Birthday Cookout”

Journal Entry – Describe an “Ah-Ha!” moment you had during this activity. It may have been in your approach to the problem or an idea shared by a classmate.

Representing Powers of Ten Using Base Ten Blocks

SUGGESTED TIME FOR THIS LESSON:

50-60 minutes

Exact timings will depend on the needs of your class.

STANDARDS FOR MATHEMATICAL CONTENT

Students will compare different representations of numbers (i.e., fractions, decimals, radicals, etc.) and perform basic operations using these different representations.

MFANSQ1. Students will analyze number relationships.

c. Explain patterns in the placement of decimal points when multiplying or dividing by powers of ten. (MGSE5.NBT.2)

d. Compare fractions and decimals to the thousandths place. For fractions, use strategies other than cross multiplication. For example, locating the fractions on a number line or using benchmark fractions to reason about relative size. For decimals, use place value. (MGSE4.NF.2; MGSE5.NBT.3,4)

MFANSQ4. Students will apply and extend previous understanding of addition, subtraction, multiplication, and division.

a. Find sums, differences, products, and quotients of multi-digit decimals using strategies based on place value, the properties of operations, and/or relationships between operations. (MGSE5.NBT.7; MGSE6.NS.3)

b. Find sums, differences, products, and quotients of all forms of rational numbers, stressing the conceptual understanding of these operations. (MGSE7.NS.1, 2)

d. Illustrate and explain calculations using models and line diagrams. (MGSE7.NS.1, 2)

Common Misconception

Students may not think about the place value of the digits when multiplying.

STANDARDS FOR MATHEMATICAL PRACTICE

1. Make sense of problems and persevere in solving them. Students solve problems by applying and extending their understanding of multiplication and division to decimals. Students seek the meaning of a problem and look for efficient ways to solve it. They determine where to place the decimal point in calculations.

2. Reason abstractly and quantitatively. Students demonstrate abstract reasoning to connect decimal quantities to fractions, and to compare relative values of decimal numbers. Students round decimal numbers using place value concepts.

3. Construct viable arguments and critique the reasoning of others. Students construct arguments using concrete referents, such as objects, pictures, and drawings. They explain calculations and placement of the decimal point, based upon models and rules that generate patterns. They explain their thinking to others and respond to others' thinking.

4. Model with mathematics. Students use base ten blocks, drawings, number lines, and equations to represent decimal place value, multiplication and division. They determine which models are most efficient for solving problems.

5. Use appropriate tools strategically. Students select and use tools such as graph or grid paper, base ten blocks, and number lines to accurately solve multiplication and division problems with decimals.

6. Attend to precision. Students use clear and precise language, (math talk) in their discussions with others and in their own reasoning. Students use appropriate terminology when referring to decimal place value and use decimal points correctly.

7. Look for and make use of structure. Students use properties of operations as strategies to multiply and divide with decimals. Students utilize patterns in place value and powers of ten to correctly place the decimal point.

8. Look for and express regularity in repeated reasoning. Students use repeated reasoning to understand algorithms and make generalizations about patterns. Students connect place value and properties of operations to fluently multiply and divide decimals.

EVIDENCE OF LEARNING/LEARNING TARGET

By the conclusion of this lesson, students should be able to:

- Multiply a decimal by a power of ten.
- Divide a decimal by a power of ten.
- Explain the result on the product when multiplying by a power of ten.

MATERIALS

- Base Ten Blocks (If base 10 blocks are not available, you can print your own representation. See the sample <https://www.illustrativemathematics.org/content-standards/5/NBT/A/2/LESSONS/1620>. *Another option is to have the students create the base 10 blocks.*

ESSENTIAL QUESTIONS

- How can you represent a decimal using base ten blocks?
- How can you multiply decimals by powers of ten?

Grouping: Individual/Partner

OPENER/ACTIVATOR:

Teacher notes: Use this activity to teach students how to use base ten blocks to represent decimals.

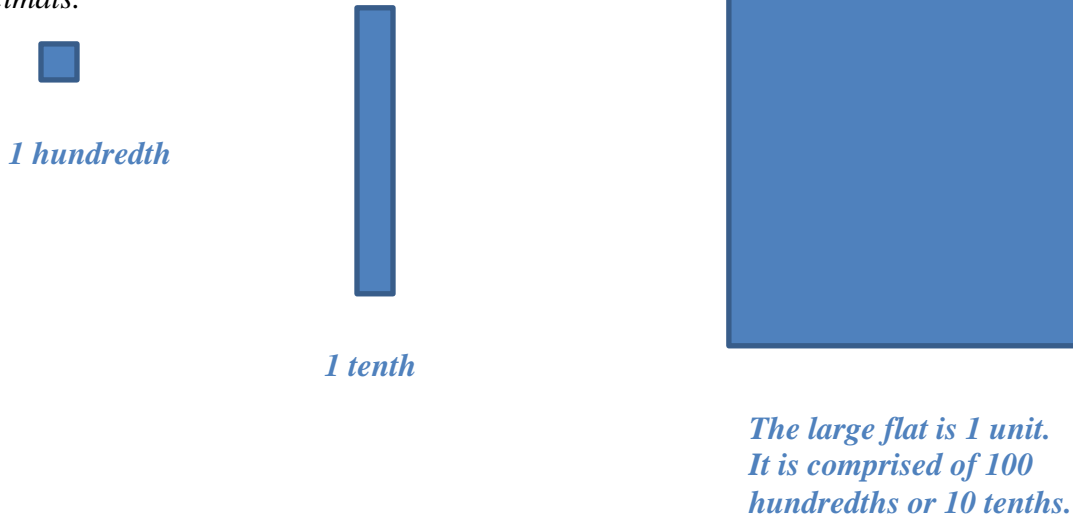

<https://www.illustrativemathematics.org/content-standards/5>

WORK SESSION

Teacher notes: In this activity, use the key provided as to the representation of the ten blocks. The single square now represent one tenths. A key is provided in link.

<https://www.illustrativemathematics.org/content-standards/5/NBT/A/2/LESSONS/1620>

INTERVENTION

For extra help with Powers of 10, please open the hyperlink [Intervention Table](#).

CLOSING/SUMMARIZER

Journal Entry: Given your explorations of multiplying decimals by the power of ten, create your own problem and illustrate how you would solve it.

Multiplying by Powers of Ten

SUGGESTED TIME FOR THIS LESSON:

50-60 minutes

Exact timings will depend on the needs of your class.

STANDARDS FOR MATHEMATICAL CONTENT

Students will compare different representations of numbers (i.e., fractions, decimals, radicals, etc.) and perform basic operations using these different representations.

MFANSQ1. Students will analyze number relationships.

c. Explain patterns in the placement of decimal points when multiplying or dividing by powers of ten. (MGSE5.NBT.2)

d. Compare fractions and decimals to the thousandths place. For fractions, use strategies other than cross multiplication. For example, locating the fractions on a number line or using benchmark fractions to reason about relative size. For decimals, use place value. (MGSE4.NF.2; MGSE5.NBT.3,4)

MFANSQ4. Students will apply and extend previous understanding of addition, subtraction, multiplication, and division.

a. Find sums, differences, products, and quotients of multi-digit decimals using strategies based on place value, the properties of operations, and/or relationships between operations. (MGSE5.NBT.7; MGSE6.NS.3)

b. Find sums, differences, products, and quotients of all forms of rational numbers, stressing the conceptual understanding of these operations. (MGSE7.NS.1, 2)

d. Illustrate and explain calculations using models and line diagrams. (MGSE7.NS.1, 2)

Common Misconception

Students may not think about the place value of the digits when multiplying.

STANDARDS FOR MATHEMATICAL PRACTICE

1. Make sense of problems and persevere in solving them. Students solve problems by applying and extending their understanding of multiplication and division to decimals. Students seek the meaning of a problem and look for efficient ways to solve it. They determine where to place the decimal point in calculations.

2. Reason abstractly and quantitatively. Students demonstrate abstract reasoning to connect decimal quantities to fractions, and to compare relative values of decimal numbers. Students round decimal numbers using place value concepts.

3. Construct viable arguments and critique the reasoning of others. Students construct arguments using concrete referents, such as objects, pictures, and drawings. They explain calculations and placement of the decimal point, based upon models and rules that generate patterns. They explain their thinking to others and respond to others' thinking.

- 4. Model with mathematics.** Students use base ten blocks, drawings, number lines, and equations to represent decimal place value, multiplication and division. They determine which models are most efficient for solving problems.
- 5. Use appropriate tools strategically.** Students select and use tools such as graph or grid paper, base ten blocks, and number lines to accurately solve multiplication and division problems with decimals.
- 6. Attend to precision.** Students use clear and precise language, (math talk) in their discussions with others and in their own reasoning. Students use appropriate terminology when referring to decimal place value and use decimal points correctly.
- 7. Look for and make use of structure.** Students use properties of operations as strategies to multiply and divide with decimals. Students utilize patterns in place value and powers of ten to correctly place the decimal point.
- 8. Look for and express regularity in repeated reasoning.** Students use repeated reasoning to understand algorithms and make generalizations about patterns. Students connect place value and properties of operations to fluently multiply and divide decimals.

EVIDENCE OF LEARNING/LEARNING TARGET

By the conclusion of this lesson, students should be able to:

- Multiply a decimal by a power of ten.
- Divide a decimal by a power of ten.
- Explain the result on the product when multiplying by a power of ten.

MATERIALS

- Internet Connection

ESSENTIAL QUESTIONS

- How can you represent a decimal using base ten blocks?
- How can you multiply decimals by powers of ten?

Grouping: Individual/Whole Group

OPENER/ACTIVATOR

Teacher Note: View the youtube video “Power of 10ⁿ” (1977). You may not want to watch the entire 9 minutes, but at least view the first couple of minutes to get the idea.

<https://www.youtube.com/watch?v=0fKBhvDjuy0>

WORK SESSION

Teacher Notes: This video will revisit the use of base ten blocks and assist in making the connection as to why the decimal point moves.

<https://learnzillion.com/lessons/2762-explain-patterns-in-the-placement-of-the-decimal-point-when-a-decimal-is-multiplied-by-a-power-of-10>

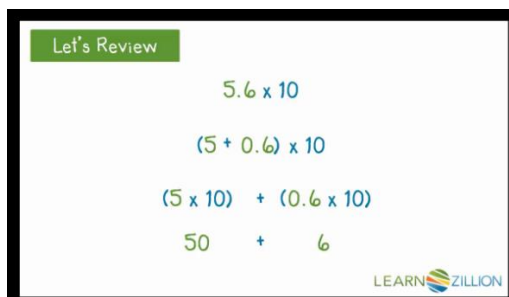

Following the video, allow students to work problems on whiteboards and to hold up their boards for a quick check or to submit their answers electronically.

Sample problems:

5.3×10

6.23×1000

83.5×100

$2.05 \times 10,000$

903.85×10

0.3856×100

Technology Option: Zombies vs. Exponents in the App Store

TEACHER NOTE: *Students should realize that the powers of 10 can be written exponentially such as $100 = 10^2$*

INTERVENTION

For extra help with powers of 10, please open the hyperlink [Intervention Table](#).

CLOSING/SUMMARIZER

Journal Entry: Ally claims that $3.4 \times 100 = 3.400$. Do you support her answer? If you do not support it, can you explain Ally's misunderstanding? Illustrate how you tell Ally to work the problem.

Adapted from Illustrative Mathematics, Marta's Multiplication Error

<https://www.illustrativemathematics.org/content-standards/5/NBT/A/2/LESSONS/1524>

Comparing Decimals

SUGGESTED TIME FOR THIS LESSON:

50-60 minutes

Exact timings will depend on the needs of your class.

STANDARDS FOR MATHEMATICAL CONTENT

Students will compare different representations of numbers (i.e., fractions, decimals, radicals, etc.) and perform basic operations using these different representations.

MFANSQ1. Students will analyze number relationships.

d. Compare fractions and decimals to the thousandths place. For fractions, use strategies other than cross multiplication. For example, locating the fractions on a number line or using benchmark fractions to reason about relative size. For decimals, use place value. (MGSE4.NF.2; MGSE5.NBT.3,4)

MFANSQ4. Students will apply and extend previous understanding of addition, subtraction, multiplication, and division.

a. Find sums, differences, products, and quotients of multi-digit decimals using strategies based on place value, the properties of operations, and/or relationships between operations. (MGSE5.NBT.7; MGSE6.NS.3)

b. Find sums, differences, products, and quotients of all forms of rational numbers, stressing the conceptual understanding of these operations. (MGSE7.NS.1,2)

d. Illustrate and explain calculations using models and line diagrams. (MGSE7.NS.1,2)

Common Misconceptions

Students often allow the length of the decimal to determine which decimal value is larger.

STANDARDS FOR MATHEMATICAL PRACTICE

1. Make sense of problems and persevere in solving them. Students solve problems by applying and extending their understanding of multiplication and division to decimals. Students seek the meaning of a problem and look for efficient ways to solve it. They determine where to place the decimal point in calculations.

2. Reason abstractly and quantitatively. Students demonstrate abstract reasoning to connect decimal quantities to fractions, and to compare relative values of decimal numbers. Students round decimal numbers using place value concepts.

3. Construct viable arguments and critique the reasoning of others. Students construct arguments using concrete referents, such as objects, pictures, and drawings. They explain calculations and placement of the decimal point, based upon models and rules that generate patterns. They explain their thinking to others and respond to others' thinking.

4. Model with mathematics. Students use base ten blocks, drawings, number lines, and equations to represent decimal place value, multiplication and division. They determine which models are most efficient for solving problems.

5. Use appropriate tools strategically. Students select and use tools such as graph or grid paper, base ten blocks, and number lines to accurately solve multiplication and division problems with decimals.

6. Attend to precision. Students use clear and precise language, (math talk) in their discussions with others and in their own reasoning. Students use appropriate terminology when referring to decimal place value and use decimal points correctly.

7. Look for and make use of structure. Students use properties of operations as strategies to multiply and divide with decimals. Students utilize patterns in place value and powers of ten to correctly place the decimal point.

8. Look for and express regularity in repeated reasoning. Students use repeated reasoning to understand algorithms and make generalizations about patterns. Students connect place value and properties of operations to fluently multiply and divide decimals.

EVIDENCE OF LEARNING/LEARNING TARGET

By the conclusion of this lesson, students should be able to show understanding of decimal numbers.

MATERIALS

- “Comparing Decimals” recording sheet

ESSENTIAL QUESTION

- How can you compare decimals?

Grouping: Individual/Partner

OPENER/ACTIVATOR

Teacher Notes: Students will use their knowledge of modeling decimals with base ten blocks to compare decimals.

Lesson with explanations can be found at:

<https://www.illustrativemathematics.org/content-standards/NBT/5/A/3/LESSONS/1801>

- Which is greater, 0.01 or 0.001? Explain. Draw a picture to illustrate your explanation.
- Which is greater, 0.03 or 0.007? Explain. Draw a picture to illustrate your explanation.
- Which is greater, 0.025 or 0.052? Explain. Draw a picture to illustrate your explanation.
- Which is greater, 0.13 or 0.031? Explain. Draw a picture to illustrate your explanation.
- Which is greater, 0.203 or 0.21? Explain. Draw a picture to illustrate your explanation.

WORK SESSION

Adapted from <http://bit.ly/1AJrqzU>

Teacher Notes: Encourage students to think of money as they work through this lesson.

Comparing Decimals

Place each of the decimals below in the correct box.

4.23

4.6

4.09

4.491

4.2

4.009

4.9

Numbers smaller than 4.5
4.23
4.09
4.491
4.2
4.009

Numbers larger than 4.5
4.6
4.9

Which number is nearest 4.5? Explain.

4.491

Students may draw pictures or explain with words that all of the numbers present have four whole units. The partial unit closest to 0.5 is 0.491. 0.5 is equivalent to 0.500 which is 500 tiny squares colored in a whole unit made of 1,000 tiny squares. 0.491 has 491 tiny squares colored in a whole unit made of 1,000 tiny squares. This is the closest.

Write the numbers in order from least to greatest.

4.009, 4.09, 4.2, 4.23, 4.491, 4.6, 4.9

Explain.

They all have four whole units and are equivalent in that regards so you must look at the partial unit. If you look at the models in terms of one thousand tiny squares in a whole unit, there are 9, 90, 200, 230, 491, 600, and then 900; hence, the answer above.

What is a number that is between 4.2 and 4.23?

Common answers may be: 4.21 and 4.22

You may have a student think in terms of thousandth as above. 4.201, 4.207, 4.229, etc.

INTERVENTION

For extra help with comparing decimals, please open the hyperlink [Intervention Table](#).

Student Edition: Comparing Decimals

Place each of the decimals below in the correct box.

4.23

4.6

4.09

4.491

4.2

4.009

4.9

Numbers smaller than 4.5



Numbers larger than 4.5



Which number is nearest 4.5? Explain.

Write the numbers in order from least to greatest.

Explain.

What is a number that is between 4.2 and 4.23?

CLOSING/SUMMARIZER

Journal Entry – Given two decimals 7.463 and 7.4063. Which is the greatest? Explain.

Integers on the Number Line

SUGGESTED TIME FOR THIS LESSON:

50-60 minutes

Exact timings will depend on the needs of your class.

STANDARDS FOR MATHEMATICAL CONTENT

Students will compare different representations of numbers (i.e., fractions, decimals, radicals, etc.) and perform basic operations using these different representations.

MFANSQ2. Students will conceptualize positive and negative numbers (including decimals and fractions).

- a. Explain the meaning of zero. (MGSE6.NS.5)
- b. Represent numbers on a number line. (MGSE6.NS.5,6)
- c. Explain meanings of real numbers in a real world context. (MGSE6.NS.5)

MFANSQ4. Students will apply and extend previous understanding of addition, subtraction, multiplication, and division.

- a. Find sums, differences, products, and quotients of multi-digit decimals using strategies based on place value, the properties of operations, and/or relationships between operations. (MGSE5.NBT.7; MGSE6.NS.3)
- b. Find sums, differences, products, and quotients of all forms of rational numbers, stressing the conceptual understanding of these operations. (MGSE7.NS.1,2)
- d. Illustrate and explain calculations using models and line diagrams. (MGSE7.NS.1,2)

STANDARDS FOR MATHEMATICAL PRACTICE

- 1. Make sense of problems and persevere in solving them.** Students solve problems by applying and extending their understanding of multiplication and division to decimals. Students seek the meaning of a problem and look for efficient ways to solve it. They determine where to place the decimal point in calculations.
- 2. Reason abstractly and quantitatively.** Students demonstrate abstract reasoning to connect decimal quantities to fractions, and to compare relative values of decimal numbers. Students round decimal numbers using place value concepts.
- 3. Construct viable arguments and critique the reasoning of others.** Students construct arguments using concrete referents, such as objects, pictures, and drawings. They explain calculations and placement of the decimal point, based upon models and rules that generate patterns. They explain their thinking to others and respond to others' thinking.
- 4. Model with mathematics.** Students use base ten blocks, drawings, number lines, and equations to represent decimal place value, multiplication and division. They determine which models are most efficient for solving problems.
- 5. Use appropriate tools strategically.** Students select and use tools such as graph or grid paper, base ten blocks, and number lines to accurately solve multiplication and division problems with decimals.

6. Attend to precision. Students use clear and precise language, (math talk) in their discussions with others and in their own reasoning. Students use appropriate terminology when referring to decimal place value and use decimal points correctly.

7. Look for and make use of structure. Students use properties of operations as strategies to multiply and divide with decimals. Students utilize patterns in place value and powers of ten to correctly place the decimal point.

8. Look for and express regularity in repeated reasoning. Students use repeated reasoning to understand algorithms and make generalizations about patterns. Students connect place value and properties of operations to fluently multiply and divide decimals.

EVIDENCE OF LEARNING/LEARNING TARGET

By the conclusion of this lesson, students should be able to:

- Identify the placement of integers on the number line.
- Use positive and negative numbers in real world context.
- Use positive and negative numbers to describe opposites.

MATERIALS

- Number Line
- Red and Yellow Flags (pieces of paper)

ESSENTIAL QUESTIONS

- How can you represent integers on the number line?
- How can you find the opposite of a number?
- How can you find the total distance between two locations on the number line?

Grouping: Whole Group

OPENER/ACTIVATOR

Teacher Notes: The teacher will share various scenarios. The students will identify these as positive (yellow flag) or negative (red flag) by raising the appropriate flag.

Situations:

- You made \$45.
- Scuba diving at 60 feet below sea level
- Lose 10 lbs.
- 3 candy bars
- Spilling 2 cups of water
- 15-yard penalty
- Made a 3-point shot
- Docked 2 hours at work
- Fell 2000 feet
- Elevation of 1500 feet above sea level

WORK SESSION

View the video: “The Number Line Dance” to hype them up.

<https://www.youtube.com/watch?v=6EWq9EZmIKg>

Discussion questions for after the video:

- How much did the little boy have after he went to the taco shop and got ice cream with his friends?
- What happened to the money he earned from washing cars?
- What makes -8 the opposite of 8?

Have the students find the number 6 on the number line. Now ask the students “What is the opposite of 6?” and “Why?” Have the students identify it on the number line.

Teacher Note: Show students the mathematical way of saying “the opposite of 6” which is -6. Also, “the opposite of a -7” is $-(-7)$.

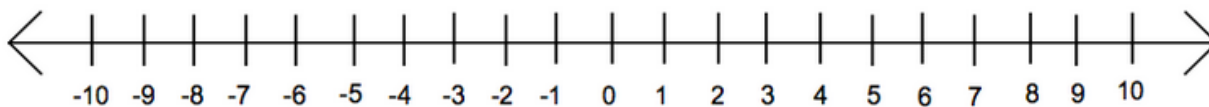

Lesson: Labeling Integers on the Number Line

Adapted from Integers on the Number Line from Illustrative Mathematics

<https://www.illustrativemathematics.org/content-standards/6/NS/C/6/LESSONS/2009>

On the number line below:

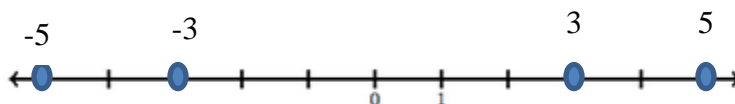

- a) Find and label the integers -3 and -5 on the number line. Explain.

Negative numbers are located to the left of zero. i.e.: -3 is three units to the left of zero

- b) Find and label the $-(-3)$ and $-(-5)$ on the number line. Explain.

The opposite of a negative 3 would place it on the other side zero; hence, a positive 3. Same for the opposite of a negative 5 would be a positive 5.

- c) Find and label -0 on the number line. Explain.

Zero is the balancing point, so, it is neither positive or negative. It is the point of equilibrium.

INTERVENTIONS

For extra help with operations with integers, please open the hyperlink [Intervention Table](#).

Student Edition:

On the number line below:

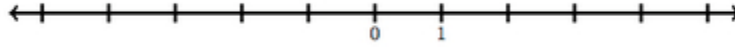

- a) Find and label the integers -3 and -5 on the number line. Explain.

- b) Find and label the $-(-3)$ and $-(-5)$ on the number line. Explain.

- c) Find and label -0 on the number line. Explain.

CLOSING/SUMMARIZER

Journal Entry: Why are the numbers 8 and -8 opposites? Write a story problem which would show this.

Translating Math

This lesson is designed to connect students' knowledge of arithmetic expressions to writing algebraic expressions. The lesson is based on the lesson from Illustrative Math <https://www.illustrativemathematics.org/content-standards/4/OA/A/2/LESSONs/263> and <https://www.illustrativemathematics.org/content-standards/LESSONs/541>

SUGGESTED TIME FOR THIS LESSON

60 to 90 minutes

The suggested time for the class will vary depending upon the needs of the students.

STANDARDS FOR MATHEMATICAL CONTENT

MFAAA1. Students will generate and interpret equivalent numeric and algebraic expressions.

e. Generate equivalent expressions using properties of operations and understand various representations within context. *For example, distinguish multiplicative comparison from additive comparison. Students should be able to explain the difference between “3 more” and “3 times”.* (MGSE4.OA.2; MGSE6.EE.3, MGSE7.EE.1, 2; MGSE9-12.A.SSE.3)

COMMON MISCONCEPTIONS

As students translate verbal mathematical expressions into symbolic expressions, they often confuse the order of operations. Special attention should be called to the order in which symbolic math is written. For example, students often translate the phrase “Sam (s) has three less than Fred (f) as $3 - f$ instead of $f - 3$. Problem #2 in the LESSON below calls attention to ordering concerns.

STANDARDS FOR MATHEMATICAL PRACTICE

1. Make sense of problems and persevere in solving them. Students make sense of properties by applying properties to generate equivalent expressions.

7. Look for and make use of structure. Students apply properties to generate equivalent expressions. Students will interpret and apply formulas.

EVIDENCE OF LEARNING/LEARNING TARGET

By the conclusion of this LESSON, students should be able to:

- Interpret and translate verbal expressions into equivalent algebraic expressions.
- Model and interpret comparative expressions.

MATERIALS

- Sticky notes may be offered as a way to build tape diagrams (bar models)

ESSENTIAL QUESTIONS

- How can you determine which mathematical operation to apply?
- How can you model and interpret mathematical expressions?

SUGGESTED GROUPING FOR THIS LESSON

Small group or pairs of students for the opening activity followed by independent practice

KEY VOCABULARY

In this LESSON, discuss terminology as it naturally arises in discussion of the problems. Allow students to point out words or phrases that lead them to the model and solution of the problems. Words that imply mathematical operations vary based on context and should be delineated based on their use in the particular problem.

OPENER/ACTIVATOR

- The opening activity sets the stage for translating verbal expressions into mathematical expressions along with reviewing methods of organizing mathematical thoughts such as the use of tables or charts. The opener is based on a Number Strings activity at <http://numberstrings.com/2014/04/01/moving-straight-ahead/>
- The dialogue below **should not be interpreted as a script** to be read to your class. It is an example of how the number string could be played in your classroom. Please modify the situation to engage your class in the activity. This number string activity will get students thinking and discussing math operations in context. Many different strategies (including tape diagram/bar model) might be used in solving this problem.
- “Suppose you are on a trip outside of New York City, riding along in a car, going at a steady rate with no traffic whatsoever. Want to roll down the window and feel the wind in your hair? You are cruising. After 45 minutes in the car, your dad says you’ve traveled 36 miles. I’m going to record the situation so far on this table.”

Time (in hours)	Distance (miles)
.75	36

- **NOTE:** you could model this situation with a bar model with the whole being one hour and the part being .25 or $\frac{1}{4}$ of an hour. The bar model will help students with a pictorial representation of the situation and can be used to complete the remaining parts.
- Some students might also benefit from looking at a clock and discussion where .75 or $\frac{3}{4}$ of an hour would be. These students benefit from a concrete representation of the problem. Others will be able to abstract the situation without a model or representation.

Georgia Department of Education
 Georgia Standards of Excellence Middle School Support
 GSE Grade 6 • Connections/Support Materials for Remediation

- “Turn and talk to your partner about whether this table captures the situation so far or whether I should have written something different. Remember you’ve driven 36 miles in 45 minutes. Does this table capture what’s happened so far? Why or why not? Who could convince us?”
- You may need to pose this question if kids are not convinced that 45 minutes is equivalent to .75 hours.

“What’s the same and what’s different about these tables?”

Time (in hours)	Distance (miles)
.75	36

Time (in minutes)	Distance (miles)
45	36

Time (in hours)	Distance (miles)
.75	36
1.5	

- “Let’s say you keep going at this rate. How far have you traveled now (after 1.5 hours)? How do you know?”
- **NOTE:** You may revisit the clock model or the bar model to progress to this and future parts.

- “What about now (after 3.0 hours)? How far have you traveled? And how do you know?”

Time (in hours)	Distance (miles)
.75	36
1.5	72
3.0	

Time (in hours)	Distance (miles)
.75	36
1.5	72
3.0	144
4.5	

- “This is a long car ride. It turns out that the whole trip took you 4.5 hours. How far have you traveled? And how do you know? I’ll give you a minute to think, and then you can talk to your partner and share your strategy. Maybe there are a few ways to think about this....”
- Expect some students will double the 144 because they will overgeneralize the pattern of doubling. That’s great if it happens because it gets kids really defending their thinking.
- If it happens that students get the incorrect answer, just record the possible distances (288 miles, 216 miles), note

that we did not agree and then let kids describe how they got their answers. It is often the

Georgia Department of Education
 Georgia Standards of Excellence Middle School Support
 GSE Grade 6 • Connections/Support Materials for Remediation

case that simply by talking through their thinking, a student will revise their ideas, “No, no, wait! I change my answer. I actually agree with 216 now. I was doubling, but the 3.0 doesn’t double to make 4.5.”

- Once again, the bar model or the clock model could be used to help students compute the solution.

“I forgot to mention an important detail: you and your dad stopped for gas at the beginning of this journey, after only 15 minutes.

- We should probably put this on the table. I’m going to add this line at the bottom. But first I’m wondering who can explain why I’m not writing “15” under time? And why .25 somehow represents 15 minutes? How could that be? Who feels like they could explain that?”
- (Access the bar or clock model as needed)
- Once the room is convinced by a student that 15 minutes is equivalent to .25 of an hour ask, “How far had you traveled at that point?”
- Look for lots of different strategies here. All of these strategies can be recorded on or near the table.

Time (in hours)	Distance (miles)
.75	36
1.5	72
3.0	144
4.5	216
.25	

One thing we haven’t even talked about is this, our last question:
How fast were you going on this trip? In other words, what was your speed? Take a moment to think about this and how you might explain it to all of us.

Time (in hours)	Distance (miles)
.75	36
1.5	72
3.0	144
4.5	216
.25	12
1.0	

Add this last value (the unit rate) to the table only if you think it will help kids. Otherwise, leave it blank until they explain their thinking.

TRANSLATING MATH LESSON

Post the following problems (or provide them in written form) one at a time for small groups or pairs of students to discuss. Instruct students to come up with a way to model the problem with a drawing, diagram, or using sticky notes. Circulate around the room to select a few groups to explain their model. Repeat this process for the remaining problems.

NOTE: For more information on tape diagrams (shown below) access one of the following links:
<https://www.louisianabelieves.com/docs/default-source/louisiana-teacher-leaders/p17-p18-presentation-eureka-math---tape-diagrams.pdf?sfvrsn=2>

<http://greatminds.net/maps/math/video-gallery/solving-word-problems-with-tape-diagrams>

<https://learnzillion.com/lessons/1744-interpret-division-as-an-unknown-factor-problem-using-a-bar-model>

a. Helen raised \$12 for the food bank last year and she raised 6 times as much money this year. How much money did she raise this year?

Solution: Tape diagram (other options are also appropriate)

She raised six times as much money (as shown in the diagram) so she raised $6 \times 12 = 72$

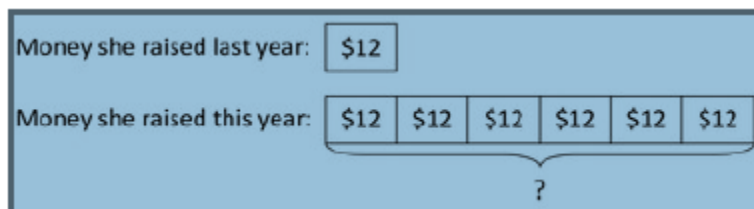

b. Sandra raised \$15 for the PTA and Nita raised \$45. How many times as much money did Nita raise as compared to Sandra?

$? \times 15 = 45$ $45 \div 15 = ?$

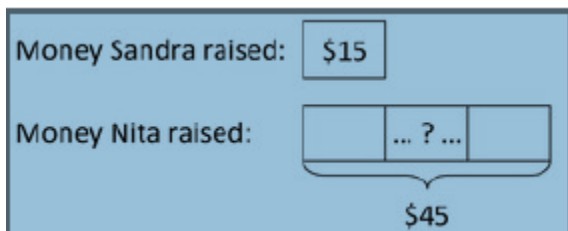

c. Luis raised \$45 for the animal shelter, which was 3 times as much money as Anthony raised. How much money did Anthony raise?

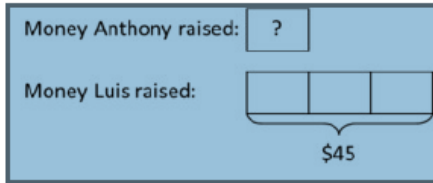

$3 \times ? = 45$ is equivalent to $45 \div 3 = ?$

Once students have worked and discussed the first three problems, pose the next problem:

2. Write an expression for the sequence of operations.
 - a. Add 3 to x, subtract the result from 1, then double what you have.
 Add 3 to x, double what you have, then subtract 1 from the result.

The instructions for the two expressions sound very similar, however, the order in which the different operations are performed and the exact wording make a big difference in the final expression. Students have to pay close attention to the wording: “subtract the result from 1” and “subtract 1 from the result” are very different.

*Solution: a) Step One $x+3$, Step Two $1-(x+3)$, Step Three $2(1-(x+3))$ simplifies to $-2x-4$
 If we choose to simplify this expression, we use the distributive, commutative and associative properties in the following way:*

$2(1-(x+3))$

$2(1-x-3)$	<i>distribute the - 1</i>
$2(-x-2)$	<i>subtracting 3 from 1</i>
$-2x-4$	<i>distribute the 2</i>

b) Step One $x+3$, Step Two $2(x+3)$, Step Three $2(x+3) - 1$ simplifies to $2x+5$ below

$2x+6 - 1$	<i>subtracting 3 from 1</i>
$2x+5$	<i>distribute the 2</i>

Call attention to the fact that the final expressions are very different, even though the instructions sounded very similar.

FORMATIVE ASSESSMENT QUESTIONS

The following questions are suggestions to gauge student understanding of mathematical translations. There are many others that teachers could establish to assess understanding.

- How can you explain your model?
- How can you convince me your method is correct?
- How did you decide which math operation to use?
- How could you solve this problem another way?

DIFFERENTIATION IDEAS

Students who struggle with translating words into symbols could be provided options at the onset of the lesson to help them better understand the problem. As students become more proficient, these options can be removed.

Students who need more challenge could be asked to devise their own problems involving one or more operations. They could then exchange problems with others. Students could also be given a bar model (tape diagram) and be asked to create a problem that could be modeled by the diagram. Students could then exchange problems to see if classmates draw a model aligned to the one provided originally.

INTERVENTION For extra help with problem solving strategy, please open the hyperlink [Intervention Table](#).

CLOSING/SUMMARIZER

Have students identify two key ideas as they reflect on the essential questions of the day. Allow several groups to share out their ideas or create a “Parking Lot” for students to post sticky notes with their ideas; this can be used for reflection during the next class meeting.

ADDITIONAL PRACTICE PROBLEMS

Please select problems from the set on the following page or generate your own problems based on the performance of your students in the lesson above. Some students will not need as much practice as others. You may scaffold the assignment to increase the rigor or provide additional cues for access to learners who might need more direction.

Generating Variable Expressions Practice

Teacher's Edition

DIRECTIONS: Write a variable expression for each situation described below. Make sure to identify your variable and be prepared to defend your expressions. In some cases, your expression may be different than that of other students based on their choice of variable.

1. One coin is seven more than twice as old as another. Represent the ages of the coins using a single variable.

Let one coin be represented by c so the other coin would be $2c+7$

2. Mrs. Drinkard's class read $(124 - 4b)$ books and Mrs. Franklin's class read $(7b + 16)$ books

a) Write an expression to show the difference between the number of books read by Mrs. Drinkard's class and the number of books read by Mrs. Franklin's class.

$(124 - 4b) - (7b + 16)$ simplifies to $108 - 11b$

**NOTE for extension: This is a good opportunity to discuss possible values of for "b" in context of this problem.*

b) Write an expression to model the total number of books read by the two classes.

$(124 - 4b) + (7b + 16)$ simplifies to $140 + 3b$

c) Based on the context of the problem (reading books), are there any possible values for b that will not make sense for evaluating the number of books that Mrs. Drinkard's class might have read? Make a statement explaining why that is the case.

If b gets larger than 31, the number of books read by Mrs. Drinkard's class would be a negative value which would not make sense in this context.

(Extension Problem provided below to preview the next module and connect equations to variable expressions)

3. The Sweet Shoppe Bakery ordered 15 dozen eggs for their upcoming project. When the bill came, they were charged \$33.75 for the eggs.

a) Write a numerical expression to represent the cost for One dozen eggs and 15 dozen eggs.

The cost for one dozen eggs could be represented by " d " so the expression for 15 dozen would be $15d$.

b) Find the cost for one dozen eggs based on your numerical expression.

Since the cost of 15 dozen eggs is given as \$33.75, we can use the relationship that $15d$ is the same as 33.75 or $15d = 33.75$ which would result in the cost of one dozen being \$2.25.

Georgia Department of Education
Georgia Standards of Excellence Middle School Support
GSE Grade 6 • Connections/Support Materials for Remediation

c) Ginger estimated the cost for one dozen eggs to be \$3.00. Was her estimate reasonable? Justify your response and come up with a way to explain how you could estimate the cost for one dozen eggs.

Answers may vary: Since she estimated \$3.00 per dozen, the bill for 15 dozen would be \$45.00. Her estimate was too high based on the given facts.

d) Chris said that he remembers when the cost for **one egg** was just a dime. Based on that cost for an egg, how much would the Sweet Shoppe have had to pay for their total egg order? What is the difference between the price they paid and this amount? Please show all your numerical expressions in getting your answers.

One dozen would cost $12 \times \$0.10$ or \$1.20 so 15 dozen would cost \$18.00. They paid \$33.75 so the difference in cost would be $\$33.75 - \18.00 or \$15.75

Generating Variable Expressions Practice

Name _____

DIRECTIONS: Write a variable expression for each situation described below. Make sure to identify your variable and be prepared to defend your expressions. In some cases, your expression may be different than that of other students based on their choice of variable.

1. One coin is seven more than twice as old as another. Represent the ages of the coins using a single variable.

2. Mrs. Drinkard's class read $(124 - 4b)$ books and Mrs. Franklin's class read $(7b + 16)$ books.

a) Write an expression to show the difference between the number of books read by Mrs. Drinkard's class and the number of books read by Mrs. Franklin's class.

b) Write an expression to model the total number of books read by the two classes.

c) Based on the context of the problem (reading books), are there any possible numbers of books that will not make sense for Mrs. Drinkard's class to have read? Make a statement explaining why that is the case.

3. The Sweet Shoppe Bakery ordered 15 dozen eggs for their upcoming project. When the bill came, they were charged \$33.75 for the eggs.

a) Write a numerical expression to find the cost for one dozen eggs.

b) Find the cost for one dozen eggs based on your numerical expression.

c) Ginger estimated the cost for one dozen eggs to be \$3.00. Was her estimate reasonable? Justify your response and come up with a way to explain how you could estimate the cost for one dozen eggs.

Georgia Department of Education
Georgia Standards of Excellence Middle School Support
GSE Grade 6 • Connections/Support Materials for Remediation

d) Chris said that he remembers when the cost for **one egg** was just a dime. Based on that cost for an egg, how much would the Sweet Shoppe have had to pay for their total egg order? What is the difference between the price they paid and this amount? Please show all your numerical expressions in getting your answers.

Additional Practice Problems for Translating Words into Variable Expressions

- The following practice problems may be used as remediation or extra practice for students who struggled with the previous lesson.

- Other uses for these problems include partner review or formative assessment questions.

Write an expression for each of the following situations.

1. Ryan weighs 13 pounds less than Jay. Jay weighs x pounds. Ryan's weight: $x - 13$

2. Susan has 52 dollars more than Jennifer. Jennifer has x dollars. Susan's money: $x + 52$

3. Brooke has 12 times as many stickers than James. James has x stickers. Brooke's sticker amount: $12x$

4. The recipe calls for triple the amount of sugar than flour. There is f amount of flour in the recipe. Amount of sugar: $3f$

5. Sade's quiz grade is six more than double Tina's quiz grade. Tina's quiz grade is x . Sade's quiz grade: $2x + 6$

6. Lauren paid x dollars for her prom dress. Becca paid 16 dollars more than Lauren. Becca's prom gown price: $x + 16$

7. Pam ran the 5k in x minutes. Alexis ran the same race in half the time that Pam ran the race. Alexis's time: $\frac{1}{2}x$ or $\frac{x}{2}$

8. The spinach grew k inches. The tomatoes grew triple the height of the spinach, less 2 inches. Tomato height: $3k - 2$

9. Each person running in the race will eat two hotdogs. Determine the number of hotdogs needed, given the amount of people running in the race.

Number of People Running	Number of Hotdogs needed
100	200
220	440
415	830
620	1240

10. Write an expression that represents the number of hotdogs needed, given the number of people running in the race. *Number of people = x Number of hotdogs = $2x$*

Translating Words into Variable Expressions Name _____

Write an expression for each of the following situations.

1. Ryan weighs 13 pounds less than Jay. Jay weighs x pounds. Ryan's weight:
2. Susan has 52 dollars more than Jennifer. Jennifer has x dollars. Susan's money:
3. Brooke has 12 times as many stickers than James. James has x stickers. Brooke's sticker amount:
4. The recipe calls for triple the amount of sugar than flour. There is f amount of flour in the recipe. Amount of sugar:
5. Sade's quiz grade is six more than double Tina's quiz grade. Tina's quiz grade is x . Sade's quiz grade:
6. Lauren paid x dollars for her prom dress. Becca paid 16 dollars more than Lauren. Becca's prom gown price:
7. Pam ran the 5k in x minutes. Alexis ran the same race in half the time that Pam ran the race. Alexis's time:
8. The spinach grew k inches. The tomatoes grew triple the height of the spinach, less 2 inches. Tomato height:
9. Each person running in the race will eat two hotdogs. Determine the number of hotdogs needed, given the amount of people running in the race.

Number of People Running	Number of Hotdogs needed
100	
220	
415	
620	

10. Write an expression that represents the number of hotdogs needed, given the number of people running in the race.

The Algebra of Magic

This task is included in the grade level framework; so teachers should consult with each other to decide whether to use this activity in support or in the regular classroom.

SUGGESTED TIME FOR THIS LESSON:

The suggested time will vary depending upon the needs of the students. An estimate would be 30 minutes/part.

STANDARDS FOR MATHEMATICAL CONTENT

Students will extend arithmetic operations to algebraic modeling.

MFAAA1. Students will generate and interpret equivalent numeric and algebraic expressions.

- a. Apply properties of operations emphasizing when the commutative property applies. (MGSE7.EE.1)
- b. Use area models to represent the distributive property and develop understandings of addition and multiplication (all positive rational numbers should be included in the models). (MGSE3.MD.7)
- c. Model numerical expressions (arrays) leading to the modeling of algebraic expressions. (MGSE7.EE.1,2; MGSE9-12.A.SSE.1,3)
- d. Add, subtract, and multiply algebraic expressions. (MGSE6.EE.3, MGSE6.EE.4, MC7.EE.1, MGSE9-12.A.SSE.3)
- e. Generate equivalent expressions using properties of operations and understand various representations within context. For example, distinguish multiplicative comparison from additive comparison. Students should be able to explain the difference between “3 more” and “3 times”. (MGSE4.0A.2; MGSE6.EE.3, MGSE7.EE.1, 2, MGSE9-12.A.SSE.3)
- f. Evaluate formulas at specific values for variables. For example, use formulas such as $A = l \times w$ and find the area given the values for the length and width. (MGSE6.EE.2)

STANDARDS FOR MATHEMATICAL PRACTICE

1. **Make sense of problems and persevere in solving them.** Students will be making sense of magic tricks involving algebraic expressions as well as creating their own.
2. **Reason abstractly and quantitatively.** Students will be reasoning through each of the tricks as they determine how each trick works. Students will need to reason with quantities of “stuff” initially before generalizing an abstract rule or expression that represents all of the steps involved.
3. **Construct viable arguments and critique the reasoning of others.** Students will create expressions and defend these expressions with their peers. Students may discover equivalent expressions and end up proving their equivalence.
4. **Model with mathematics.** Students will use models to represent what happens in each trick in order to understand the trick, undo the trick, invent new tricks, and realize the value of representation.

6. Attend to precision. Students will attend to precision through their use of the language of mathematics as well as in their use of operations.

7. Look for and make use of structure. Students will show an understanding of how numbers and variables can be put together as parts and wholes using representations of operations and properties.

ESSENTIAL QUESTIONS

- How is the order of operations used to evaluate expressions?
- How are properties of numbers helpful in evaluating expressions?
- What strategies can I use to help me understand and represent real situations using algebraic expressions?
- How are the properties (Identify, Associative and Commutative) used to evaluate, simplify and expand expressions?
- How is the Distributive Property used to evaluate, simplify and expand expressions?
- How can I tell if two expressions are equivalent?

MATERIALS REQUIRED

- Computer and projector or students with personal technology (optional)
- Directions for mathematical magic tricks (attached)
- Counters
- Sticky notes or blank pieces of paper-all the same size (several per student)

The goals of these tasks are for students to:

- develop an understanding of linear expressions and equations in a context;
- make simple conjectures and generalizations;
- add expressions, ‘collect like terms’;
- use the distributive law of multiplication over addition in simple situations;
- develop an awareness that algebra may be used to prove generalizations in number situations.

Note: The context of magic tricks can often turn students off since it may lead students to imply that math is just a bunch of tricks. Presenting this with a video of a middle school student performing the trick (see links below) for someone else helps to dispel this myth. When students see another student perform this trick, they are more apt to ask “How did they do that?” or, better yet, “Why does that work?” This is what we should all strive for in our lessons. Students asking how to do something or wondering why something works means we’ve evoked curiosity and wonder.

While you can perform the tricks yourself, please be mindful of the fact that most people do not like to be fooled, and students can be intimidated by this especially in front of their peers. Another option would be to teach a trick to a student in one of your classes ahead of time. The student will know the trick (how it works), but he/she will probably not know why. The student can still investigate this.

After each trick is presented, either through the video or in another manner, students can go the link posted for each trick and try different numbers and look for patterns. The link is not necessary, but it does take the “trick” out of the picture and allows students to investigate without being intimidated by being tricked.

Explain to students that, for each trick in this task, they should:

- *investigate the trick, trying different numbers;*
- *work out how the trick is done. This usually involves spotting a connection between a starting number and a finishing number. Algebra will be helpful here: representing the unknown number (the number that is thought of) with something that can contain a quantity may be helpful at first;*
- *improve the trick in some way.*

Trick 1: A Math-ic Prediction

This 3-act task can be found at: <http://mikewiernicki3act.wordpress.com/a-math-ic-prediction/>

NOTE: The 3-act template is located after Trick 3.

In part one of this series of tasks, students will interact with a computer program that can “read minds.” Then, students will tell what they noticed. They will then be asked to discuss what they wonder or are curious about. These questions will be recorded on a class chart or on the board. Students will then use mathematics, specifically algebraic reasoning, to answer their own questions. Students will be given information to solve the problem based on need. When they realize they do not have the information they need, and ask for it, it will be given to them.



Students choose any number and follow the steps given by the teacher or the interactive app (link is at the end of this description). The prediction of “1” is revealed after the steps are followed.

Steps to follow for this trick:



- Think of a number.
- Add 3.
- Double the result.
- Subtract 4.
- Divide the result by 2.
- Subtract your original number.

The prediction for this trick is the same every time: 1.

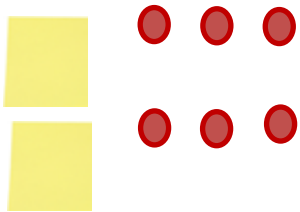
Students may wish to try larger or even smaller numbers, **integers, fractions or decimals** to see if any numbers will not work. This can be a nice way to check their understandings and fluency with operations using rational numbers. **NOTICE:** a **post-it note** is used for x
An example:

<i>Think of a number.</i>		x
<i>Add 3.</i>		$x + 3$
<i>Double the result.</i>		$2(x + 3)$ or $2x + 6$

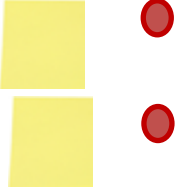
Georgia Department of Education
 Georgia Standards of Excellence Middle School Support
 GSE Grade 6 • Connections/Support Materials for Remediation

<i>Subtract 4.</i>		$2(x + 1)$ or $2x + 2$
<i>Divide by 2.</i>		$x + 1$
<i>Subtract your original number.</i>		1

The post-its work well because as students begin to visualize what is happening, they can easily write a variable on the post-it. The post-it becomes a variable and can be written in an expression as seen in the right hand column.

NOTE: Students should not be shown the table above. Students should make sense of the mathematics involved in this prediction, creating their own representations and expressions.

A Mathic Prediction interactive app: <http://scratch.mit.edu/projects/21248672/>

More information, along with guidelines for 3-Act Tasks, may be found in the Comprehensive Course Guide.

ACT 1:

Open the link above and have the program perform for students. Alternatively, perform this trick for students.

Ask students what they noticed and what they wonder (are curious about). Record student responses.

Have students hypothesize how the trick works. How can it come out to be 1 for any number chosen?

ACT 2:

Students work on determining how the trick works based on their hypothesis. They should be guided to show what is happening in the trick first through the use of some model that can be represented in a diagram, then later written as an expression. Students may ask for information such as what were the steps in the trick. When they ask, give them the steps:

Think of a number.

Add 3.

Double the result.

Subtract 4.

Divide the result by 2.

Subtract your original number.

Students may also ask for materials to use to model what is happening – these can be suggested, carefully, by the teacher.

ACT 3

Students will compare and share solution strategies.

- Share student solution paths. Start with most common strategy.
- Students should explain their thinking about the mathematics in the trick.
- Ask students to hypothesize again about whether any number would work – like fractions or decimals. Have them work to figure it out.
- Revisit any initial student questions that were not answered.

Students can be given practice after showing understanding, with a table similar to the following:

Words	Pictures	Diagrams	Hailee	Connor	Lura	Maury
Think of a number			7			
Double it				22		
Add 8					16	
Divide by 2						7

Intervention:

Students needing support might be given simpler tricks at first, building up to the trick presented above. A simple trick might be:

Prediction is 6.

- Start with 2.
- Think of a number and add it to the 2.
- Add 4.
- Subtract your original number.

Work with students on making sense of this and build the tricks up to the trick presented above.

Trick 2: Consecutive Number Sum

In parts 2 and 3 of this series of tasks, students will either watch a student perform the trick (2) or a screencast of a student performing a super quick calculation (3). Students will then tell what they noticed. They will then be asked to discuss what they wonder or are curious about. These questions will be recorded on a class chart or on the board. Students will then use mathematics, specifically algebraic reasoning, to answer their own questions. Students will be given information to solve the problem based on need. When they realize they do not have the information they need, and ask for it, it will be given to them.

Students choose any start number. The next four numbers are the four consecutive numbers that follow the chosen number. The trick is to tell the sum of the series of numbers knowing only the start number.

In the investigation of this trick, students may vary the starting numbers and make conjectures about the sums produced.

For example:

Students may decide that the sum is always a multiple of 5.

Some may use the following reasoning:

You start with a number, and then add a number that is one more, and then you add a number that's two more, then three more, then four more. That makes ten more altogether. So you add ten to five times the number.

Start Number	n
	$n + 1$
	$n + 2$
	$n + 3$
+	$n + 4$
	$5n + 10$

This table should not be shown to students.

Encourage students to show this more formally, by using a post-it or a blank card for the first number (n), a blank card and a counter ($n + 1$) for the second, a blank card and 2 counters for the third ($n + 2$) and so on. The final total obtained is 5 cards and 10 counters ($5n + 10$) or $5(n + 2)$. A quick way to predict the total from any starting number is to multiply by 5 and then add 10, or add 2 and then multiply by 5. Students may be encouraged to develop this situation into a more complex number trick. It could be made more impressive by having more addends, or changing consecutive numbers to consecutive even (or odd) numbers, for example.

An interactive app for this trick can be found here:

<http://scratch.mit.edu/projects/20832805/>

ACT 1:

Have a student perform the trick for Act 1. Ask students what they noticed and what they wonder (are curious about). Record student responses.

Have students hypothesize how the trick works. How can the performer know the sum so quickly for any number chosen?

ACT 2:

Students work on determining how the trick works based on their hypothesis. They should be guided to show what is happening in the trick first through the use of some model that can be represented in a diagram, and then later written as an expression. Students may ask for information such as: “How were the other numbers generated after the start number was chosen?” When they ask, point them to the link below or copy the numbers generated in the trick on the board so students can use them.

Students may ask if they can do the trick using technology:

<http://scratch.mit.edu/projects/20832805/>

Students may also ask for materials to use to model what is happening. (they may even ask to use similar materials from the previous task) – materials can also be suggested, carefully, by the teacher.

ACT 3

Students will compare and share solution strategies.

- Share student solution paths. Start with most common strategy.
- Students should explain their thinking about the mathematics in the trick.
- Ask students to hypothesize again about whether any number would work – like fractions or decimals. Have them work to figure it out.
- Be sure to help students make connections between equivalent expressions (i.e. the rules $5n + 10$ and $5(n + 2)$).
- Revisit any initial student questions that were not answered.

Intervention:

Students needing support might be given simpler tricks at first, building up to the trick presented above. A simple trick might be to only use 3 numbers rather than 5 to determine the sum. Use materials as well as variables to build the algebraic understanding through the use of the quantities being represented.

Trick 3: Triangle Mystery . . .

The following 3-act task can be found at: <http://mikewiernicki3act.wordpress.com/triangle-mystery/>

This trick extends the previous trick. There are more patterns to look for and many ways to determine the rules for the patterns (it's more open!). Students should be told how the triangle mystery works: in the bottom row are consecutive numbers beginning with the number chosen. Each box in the second row is the sum of the 3 boxes below (see the diagram). The top box is the sum of the three boxes in the middle row. The trick is to determine the top number of the triangle, given only the start number (in the lower left hand box).

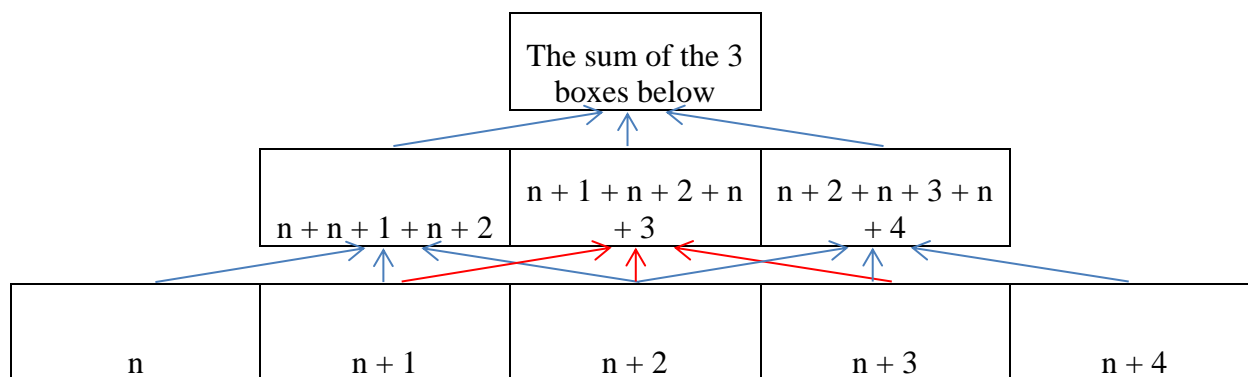

This table (with the expressions) should not be shown to students.

Tell students, prior to the trick, that:

- The bottom row of this triangle contains consecutive numbers.
- Each other number is found by adding the three numbers beneath it.

Presentation:

Give students the opportunity to change the start number in the bottom left hand rectangle and to tell what it is.

You immediately say the top number.

How is the trick done?

Try to make the trick more impressive.

Here is what the students' productive struggle will lead to:

In Triangle Mystery, if the bottom left hand number is called x , then:

- the bottom row is $x, x + 1, x + 2, x + 3, x + 4$;
- the second row is $3x + 3, 3x + 6, 3x + 9$;
- the top row is $9x + 18 = 9(x + 2)$.

So the short cut is simply to add 2 to the bottom left hand number and then multiply by 9 (or multiply the first number by 9 and add 18). Students may like to try creating larger Pyramids that follow different rules.

ACT 1:

Watch the video for Act 1 <http://mikewiernicki3act.wordpress.com/triangle-mystery/>
Alternatively, [perform](#) this trick for students. Ask students what they noticed and what they wonder (are curious about). Record student responses.

Have students hypothesize how the trick works. How can the performer know the number at the top of the triangle so quickly for any number chosen?

ACT 2:

Students work on determining how the trick works based on their hypothesis. They should be guided to show what is happening in the trick first through the use of some model that can be represented in a diagram, and then later written as an expression. Students may ask for information such as: “How were the other numbers generated after the start number was chosen?” When they ask, you can tell them the bottom row are consecutive numbers after the start number. Each number in the middle row is the sum of the 3 numbers below. The top number is the sum of the numbers in the middle row. OR you can give them the technology link below for further investigation.

Students may ask if they can investigate the trick using technology:

<http://scratch.mit.edu/projects/20831707/>

Students may also ask for materials to use (they may even ask to use similar materials from the previous task) – these can also be suggested, carefully, by the teacher.

ACT 3

Students will compare and share solution strategies.

- Share student solution paths. Start with most common strategy.
- Students should explain their thinking about the mathematics in the trick.
- Ask students to hypothesize again about whether any number would work – like fractions or decimals. Have them work to figure it out.
- Be sure to help students make connections between equivalent expressions (i.e. the expressions $9n + 18$ and $9(n + 2)$).
- Revisit any initial student questions that weren't answered.

Intervention:

Students needing support might be given simpler tricks at first, building up to the trick presented above. A simple trick might use 3 rows, but the second row may be determined by adding only the two numbers below it. Use materials as well as variables to build the algebraic understanding through the use of the quantities being represented.

Extension:

To extend all of these, students could find a way to give this trick more of a “wow” factor or to make it more impressive. Students could also develop their own trick with representations and algebraic expressions that explain it. Finally, students should be encouraged to develop (code) their own computer program for a trick like this. The free online coding program used for the tricks in this task and others to come can be found at www.scratch.mit.edu.

Georgia Department of Education
Georgia Standards of Excellence Middle School Support
GSE Grade 6 • Connections/Support Materials for Remediation

Task Title: _____

Name: _____

Adapted from Andrew Stadel

ACT 1

What did/do you notice?

What questions come to your mind?

Main Question: _____

Make a hypothesis. How do you think this works?

ACT 2

What information do you have, would like to know, or do you need to help you answer your MAIN question?

Record the given information (measurements, materials, etc.)

Act 2 (cont.)

Use this area for your work, tables, calculations, sketches or other representations, and final solution.

ACT 3

What was the result? How do you know this is correct?

Which Standards for Mathematical Practice did you use?	
<input type="checkbox"/> Make sense of problems & persevere in solving them	<input type="checkbox"/> Use appropriate tools strategically.
<input type="checkbox"/> Reason abstractly & quantitatively	<input type="checkbox"/> Attend to precision.
<input type="checkbox"/> Construct viable arguments & critique the reasoning of others.	<input type="checkbox"/> Look for and make use of structure.
<input type="checkbox"/> Model with mathematics.	<input type="checkbox"/> Look for and express regularity in repeated reasoning.

The Sequel: How would you give this Algebra Magic Trick more of a “Wow” factor?

Orange Fizz Experiment

In this lesson, students analyze concentrations in soda formulas to make a recommendation to a cola company.

SUGGESTED TIME FOR THIS LESSON:

Exact timings will depend on the needs of your class.

Recommended time: 90-120 minutes. Recommended arrangement: individual, partners or small groups.

STANDARDS FOR MATHEMATICAL CONTENT

Students will use ratios to solve real-world and mathematical problems.

MFAPR1. Students will explain equivalent ratios by using a variety of models. *For example, tables of values, tape diagrams, bar models, double number line diagrams, and equations.* (MGSE6.RP.3)

MFAPR2. Students will recognize and represent proportional relationships between quantities.

- a. Relate proportionality to fraction equivalence and division. *For example, $\frac{3}{6}$ is equal to $\frac{4}{8}$ because both yield a quotient of $\frac{1}{2}$ and, in both cases, the denominator is double the value of the numerator.* (MGSE4.NF.1)
- b. Understand real-world rate/ratio/percent problems by finding the whole given a part and find a part given the whole. (MGSE6.RP.1,2,3;MGSE7.RP.1,2)
- c. Use proportional relationships to solve multistep ratio and percent problems. (MGSE7.RP.2,3)

STANDARDS FOR MATHEMATICAL PRACTICE

- 1. Make sense of problems and persevere in solving them.** Students must make sense of the problem in order to devise a plan for solving it.
- 2. Reason abstractly and quantitatively.** Students must use quantitative reasoning to create a representation of the problem and to understand how the quantities relate.
- 3. Construct viable arguments and critique the reasoning of others.** Throughout the problem, students will need to communicate their mathematical thinking to their peers as they evaluate their own and their peers' understanding of the problem. Most importantly, they will need to construct a coherent argument for their final recommendation.
- 6. Attend to precision.** Students must use correct mathematical language as they communicate their thinking to their peers.
- 7. Look for and make use of structure.** In order to create an accurate model, students must notice patterns in order to make equivalent ratios.

EVIDENCE OF LEARNING/LEARNING TARGET

By the conclusion of this lesson, students should be able to:

- Compare ratios using a variety of strategies.
- Make part-to-part comparisons and part-to-whole comparisons.
- Find equivalent ratios.

MATERIALS

- Student lesson sheet

ESSENTIAL QUESTIONS

- How can ratios be used to make decisions?
- How do I solve real-world problems using equivalent ratios?
- What are the differences in part-to-part and part-to-whole comparisons?

OPENER/ACTIVATOR

Number Talk

Begin with the following problem, **“There are 12 boys and 18 girls in Ms. Dade’s class. What is the boy to girl ratio in the class?”** Record the problem on the far left side of the board.

Provide students with wait time as they work to mentally solve this problem. When the majority of the students have given the “thumbs up” signal, call on several students (3-4) to share their answer and the strategy they used to solve. Record the information provided by the students exactly how it is told to you. It is important to allow students ownership of their thinking.

Record, **“Mr. Hill has 30 students. 14 of the students are boys. What is the ratio of boys in the class?”** on the board next to the previous problem. Provide students with wait time as they work to mentally solve this problem. When majority of the students have given the “thumbs up” signal, call on several students (3-4) to share their answer and the strategy they used to solve. Record the information provided by the students exactly how it is told to you.

Record, **“The ratio for male and female students in Ms. Dade’s class is 12:18. The ratio of males in Mr. Hill’s entire class is 14 to 30. Whose class is composed of more boys?”** on the board towards the right. Provide students with wait time as they work to mentally solve this problem. When majority of the students have given the “thumbs up” signal, call on several students (3-4) to share their answer and the strategy they used to solve. Record the information provided by the students exactly how it is told to you.

Record, “Mrs. Ford’s class has 14 boys and 16 girls. Of the 3 classes, whose class is composed of the most boys?” on the board towards the far right. Provide students with wait time as they work to mentally solve this problem. When majority of the students have given the “thumbs up” signal, call on several students (3-4) to share their answer and the strategy they used to solve. Record the information provided by the students exactly how it is told to you.

At the end of the Number Talk, discuss the strategies used to find the answers. Talk with the students about which strategy was most efficient (quick, easy and accurate).

Prior to the lesson students need to discuss and explore making comparisons with ratios, percents, and fractions. Models and drawings, as illustrated below, may facilitate student understanding.

Relate the strategies from the introductory problems to the lesson where students will be comparing the mixes. Make these connections during the whole-group discussion.

Compare the ratio you found for Ms. Dade’s class to the ratio you found for Mr. Hill’s class. What is alike or different about each?

#1 is comparing part-to-part and #2 is comparing part-to-whole. Discuss how to compare the two classes using tables, percentages, common denominators or models. When #1 is set up as part-to-whole (12: 30), a comparison can be made easily using common denominators. The model below also illustrates the comparison.

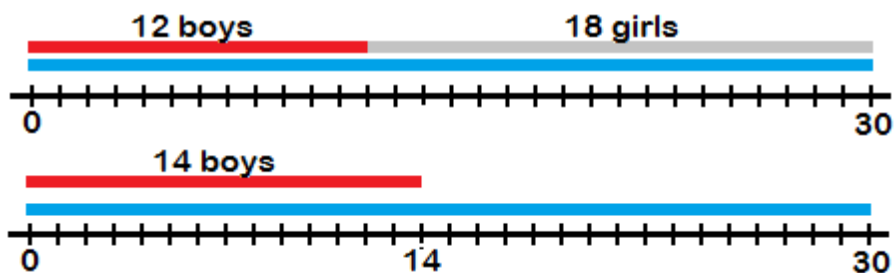

LESSON DESCRIPTION, DEVELOPMENT AND DISCUSSION

Lesson Directions:

Due to the length of the lesson, the teacher will likely need to chunk the lesson into sections. Students may have trouble completing the tables for each formula as the difficulty increases. The teacher may need to check for understanding of creating equivalent ratios after the Formula A table. Later on in the lesson, students may struggle with converting cups to gallons. Encourage students to check their solutions with group members on the three formula tables before completing the tables in #2.

FORMATIVE ASSESSMENT QUESTIONS

- What relationship do you see between the values that would help find an equivalent ratio?
- When should you round a value to assure you have the most accurate solution?
- What factors must you consider when writing a recommendation?

INTERVENTION

For extra help with proportions, please open the hyperlink [Intervention Table](#).

CLOSING/SUMMARIZER

After giving students adequate time to write a recommendation to the company, ask students to share their recommendation with their group members. Each group should work to summarize the recommendations for their group and then one student in each group will share the summary with the class. Students will need reminding that their recommendations, and summary, should include supporting data.

Orange Fizz Experiment

A famous cola company is trying to decide how to change their drink formulas to produce the best tasting soda drinks on the market. The company has three different types of formulas to test with the public. The formula consists of two ingredients: orange concentrate and carbonated water.

You are a scientist working for this company, and you will get paid a large commission if you can find the right formula that will sell the best. Your job is to decide the best formula based on cost and popularity in the taste test.

Using the company's new formulas, you must follow the recipe to the strict guidelines:

Formula A: 1 tablespoons of orange concentrate to 2 tablespoons of carbonated water

Formula B: 2 tablespoons of orange concentrate to 5 tablespoons of carbonated water

Formula C: 2 tablespoons of orange concentrate to 3 tablespoons of carbonated water

Part A: *Using part-to-whole comparison*

1. Which formula will make a drink that has the *strongest* orange taste? Show your work and explain your choice.

Answers will vary.

$$A: \frac{\text{orange}}{\text{water}} = \frac{1}{2} \qquad \frac{\text{orange}}{\text{total}} = \frac{1}{3} \qquad 33\% \text{ orange}$$

$$B: \frac{\text{orange}}{\text{water}} = \frac{2}{5} \qquad \frac{\text{orange}}{\text{total}} = \frac{2}{7} \qquad 29\% \text{ orange}$$

$$C: \frac{\text{orange}}{\text{water}} = \frac{2}{3} \qquad \frac{\text{orange}}{\text{total}} = \frac{2}{5} \qquad 40\% \text{ orange}$$

Formula C is 40% orange concentrate so it has the strongest orange taste.

2. Which formula has the highest percentage of carbonated water in the mixture? Estimations may be used. Show your work and justify your answer.

Answers will vary.

$$A: \quad \text{water:total} \quad 2:3 \qquad 67\%$$

$$B: \quad \text{water:total} \quad 5:7 \qquad 71\%$$

$$C: \quad \text{water:total} \quad 3:5 \qquad 60\%$$

Formula B contains the highest percentage of water at 71%.

Georgia Department of Education
 Georgia Standards of Excellence Middle School Support
 GSE Grade 6 • Connections/Support Materials for Remediation

Part B: Using part-to-part comparison

1. For researchers to test their product, they will need to produce enough of each of the three drink formulas to take to various locations around the area for taste testing. Researchers would like for *at least 100 people* to sample each formula. Each sample will contain 1 cup of liquid.

Formula A: 1 cup of orange concentrate to 2 cups of carbonated water

Formula B: 2 cups of orange concentrate to 5 cups of carbonated water

Formula C: 2 cups of orange concentrate to 3 cups of carbonated water

Fill in the table to determine the least amount of orange concentrate and carbonated water that you would have to use to serve 1 cup servings to 100 people.

Formula A		
Orange Concentrate (cups)	Carbonated Water (cups)	Total Amount (cups/servings)
1	2	3 cups (3 servings)
2	4	6 cups (6 servings)
3	6	9 cups (9 servings)
...
17	34	51 cups (51 servings)
...
33	66	99 cups (99 servings)
34	68	102 cups (102 servings)
35	70	105 cups (105 servings)

I. How much orange concentrate and carbonated water is needed to serve at least 100 people?

- a. Orange Concentrate - **34**
- b. Carbonated Water - **68**

Georgia Department of Education
 Georgia Standards of Excellence Middle School Support
 GSE Grade 6 • Connections/Support Materials for Remediation

Formula B		
Orange Concentrate (cups)	Carbonated Water (cups)	Total Amount (cups/servings)
2	5	7 cups (7 servings)
4	10	14 cups (14 servings)
8	20	28 cups (28 servings)
...
14	35	49 cups (49 servings)
...
26	65	91 cups (91 servings)
28	70	98 cups (98 servings)
30	75	105 cups (105 servings)

- II. How much orange concentrate and carbonated water is needed to serve at least 100 people?
- Orange Concentrate - **30**
 - Carbonated Water - **75**

Formula C		
Orange Concentrate (cups)	Carbonated Water (cups)	Total Amount (cups/servings)
2	3	5 cups (5 servings)
4	6	10 cups (10 servings)
6	9	15 cups (___ servings)
...
20	30	50 cups (50 servings)
...
36	54	90 cups (90 servings)
38	57	95 cups (95 servings)
40	60	100 cups (100 servings)

- III. How much orange concentrate and carbonated water is needed to serve at least 100 people?
- Orange Concentrate - **40**
 - Carbonated Water - **60**

Georgia Department of Education
 Georgia Standards of Excellence Middle School Support
 GSE Grade 6 • Connections/Support Materials for Remediation

2. Your lab technician will be bringing you all of the supplies that you will need in order to make the formulas at the sites. Record the number of cups needed of each ingredient in each formula in the following table.

	Orange Concentrate	Carbonated Water
Formula A	<i>34</i>	<i>68</i>
Formula B	<i>30</i>	<i>75</i>
Formula C	<i>40</i>	<i>60</i>
Total (cups)	<i>104</i>	<i>203</i>

Both orange concentrate and carbonated water are sold by the gallon. In the table below, record the number of gallons needed for both ingredients in each formula. (1 gallon = 16 cups)

	Orange Concentrate		Carbonated Water	
	Amount in gallons	Cost	Amount in gallons	Cost
Formula A	<i>2.13</i>	<i>\$20.24</i>	<i>4.25</i>	<i>\$11.69</i>
Formula B	<i>1.88</i>	<i>\$17.86</i>	<i>4.69</i>	<i>\$12.90</i>
Formula C	<i>2.5</i>	<i>\$23.75</i>	<i>3.75</i>	<i>\$10.31</i>
Total	<i>6.51</i>	<i>\$61.85</i>	<i>12.69</i>	<i>\$34.90</i>

A gallon of orange concentrate costs \$9.50 and a gallon of carbonated water costs \$2.75. Record the cost of each ingredient for each formula in the table above.

Based on the number of gallons you will need to produce Formulas A, B, and C for 100 people, which formula is most cost effective? Justify your answer.

Answers will vary.

Formula A: \$31.93

Formula B: \$30.76

Formula C: \$34.06

Formula B is the most cost effective choice at \$30.76.

The table below shows the number of taste testers who preferred each formula:

Formula A	Formula B	Formula C
30	25	45

Which formula did taste testers like best? What fraction of the taste testers liked this formula the best?

Answers will vary.

Taste testers prefer formula C. $\frac{9}{20}$ of the taste testers prefer formula C.

Write a recommendation to the company for the formula you think should be produced. Be sure to write a clear and concise recommendation for your formula using data to support your argument.

Answers will vary.

Students may argue that although formula B was the least favorite flavor, it should be produced due to the lower cost to produce it. On the other hand, some could argue that despite being the most expensive flavor to produce, the company should produce the most popular flavor, Formula C. Lastly, an argument could be made to produce Formula B because it is “in the middle” in terms of cost and popularity.

Regardless of the formula students recommend, they should refer to both the cost and the popularity of the taste of the products to construct a viable argument.

Orange Fizz Experiment

A famous cola company is trying to decide how to change their drink formulas to produce the best tasting soda drinks on the market. The company has three different types of formulas to test with the public. The formula consists of two ingredients: orange concentrate and carbonated water.

You are a scientist working for this company, and you will get paid a large commission if you can find the right formula that will sell the best. Your job is to decide the best formula based on cost and popularity in the taste test.

Using the company's new formulas, you must follow the recipe to the strict guidelines:

Formula A: 1 tablespoons of orange concentrate to 2 tablespoons of carbonated water

Formula B: 2 tablespoons of orange concentrate to 5 tablespoons of carbonated water

Formula C: 2 tablespoons of orange concentrate to 3 tablespoons of carbonated water

Part A: *Using part-to-whole comparison*

1. Which formula will make a drink that has the *strongest* orange taste? Show your work and explain your choice.

2. Which formula has the highest percentage of carbonated water in the mixture? Estimations may be used. Show your work and justify your answer.

Georgia Department of Education
 Georgia Standards of Excellence Middle School Support
 GSE Grade 6 • Connections/Support Materials for Remediation

Part B: *Using part-to-part comparison*

1. For researchers to test their product, they will need to produce enough of each of the three drink formulas to take to various locations around the area for taste testing. Researchers would like for *at least 100 people* to sample each formula. Each sample will contain 1 cup of liquid.

Formula A: 1 cup of concentrate to 2 cups of carbonated water

Formula B: 2 cups of concentrate to 5 cups of carbonated water

Formula C: 2 cups of concentrate to 3 cups of carbonated water

Fill in the table to determine the least amount of orange concentrate and carbonated water that you would have to use to serve 1 cup servings to 100 people.

Formula A		
Orange Concentrate (cups)	Carbonated Water (cups)	Total Amount (cups/servings)
1	2	3 cups (3 servings)
2	4	6 cups (6 servings)
3	6	9 cups (9 servings)
...
17	34	51 cups (51 servings)
...
33	66	___ cups (___ servings)
34		___ cups (___ servings)
	70	___ cups (___ servings)

- I. How much orange concentrate and carbonated water is needed to serve at least 100 people?
- Orange Concentrate -
 - Carbonated Water -

Georgia Department of Education
 Georgia Standards of Excellence Middle School Support
 GSE Grade 6 • Connections/Support Materials for Remediation

Formula B		
Orange Concentrate (cups)	Carbonated Water (cups)	Total Amount (cups/servings)
2	5	7 cups (7 servings)
4	10	14 cups (14 servings)
8		28 cups (28 servings)
...
	35	___ cups (49 servings)
...
26		___ cups (___ servings)
		98 cups (98 servings)
		___ cups (___ servings)

II. How much orange concentrate and carbonated water is needed to serve at least 100 people?

- a. Orange Concentrate -
- b. Carbonated Water -

Formula C		
Orange Concentrate (cups)	Carbonated Water (cups)	Total Amount (cups/servings)
2	3	5 cups (5 servings)
4	6	10 cups (10 servings)
		15 cups (___ servings)
...
20		___ cups (___ servings)
...
36		___ cups (___ servings)
	57	___ cups (___ servings)
		___ cups (___ servings)

III. How much orange concentrate and carbonated water is needed to serve at least 100 people?

- a. Orange Concentrate -
- b. Carbonated Water -

Georgia Department of Education
 Georgia Standards of Excellence Middle School Support
 GSE Grade 6 • Connections/Support Materials for Remediation

2. Your lab technician will be bringing you all of the supplies that you will need in order to make the formulas at the sites. Record the number of cups needed of each ingredient in each formula in the following table.

	Orange Concentrate	Carbonated Water
Formula A		
Formula B		
Formula C		
Total (cups)		

Both orange concentrate and carbonated water are sold by the gallon. In the table below, record the number of gallons needed for both ingredients in each formula. (1 gallon=16 cups)

	Orange Concentrate		Carbonated Water	
	Amount in gallons	Cost	Amount in gallons	Cost
Formula A				
Formula B				
Formula C				
Total				

A gallon of orange concentrate costs \$9.50 and a gallon of carbonated water costs \$2.75. Record the cost of each ingredient for each formula in the table above.

Based on the number of gallons you will need to produce Formulas A, B, and C for 100 people, which formula is most cost effective? Justify your answer.

The table below shows the number of taste testers who preferred each formula:

Formula A	Formula B	Formula C
30	25	45

Which formula did taste testers like best? What fraction of the taste testers liked this formula the best?

Georgia Department of Education
Georgia Standards of Excellence Middle School Support
GSE Grade 6 • Connections/Support Materials for Remediation

Write a recommendation to the company for the formula you think should be produced. Be sure to write a clear and concise recommendation for your formula using data to support your argument.

Which Is the Better Deal?

SUGGESTED TIME FOR THIS LESSON:

Exact timings will depend on the number of group presentations.

Recommended arrangement: partners or small groups

STANDARDS FOR MATHEMATICAL CONTENT



Students will use ratios to solve real-world and mathematical problems.

MFAPR2. Students will recognize and represent proportional relationships between quantities.

- Relate proportionality to fraction equivalence and division. *For example, $\frac{3}{6}$ is equal to $\frac{4}{8}$ because both yield a quotient of $\frac{1}{2}$ and, in both cases, the denominator is double the value of the numerator.* (MGSE4.NF.1)
- Understand real-world rate/ratio/percent problems by finding the whole given a part and find a part given the whole. (MGSE6.RP.1,2,3;MGSE7.RP.1,2)
- Use proportional relationships to solve multistep ratio and percent problems. (MGSE7.RP.2,3)

STANDARDS FOR MATHEMATICAL PRACTICE

- 1. Make sense of problems and persevere in solving them.** Students must make sense of the problem in order to understand how unit rates can help make better decisions.
- 3. Construct viable arguments and critique the reasoning of others.** Students will analyze their results and will construct a concise argument of their findings.
- 6. Attend to precision.** Students must use precise mathematical language when presenting their findings.

EVIDENCE OF LEARNING/LEARNING TARGET

By the conclusion of this lesson, students should be able to:

- Use a unit rate to make decisions when making purchases.
- Use unit rates to compare the value of products.
- Write their data in a table and graph their findings

MATERIALS

- Chart paper or white poster board
- Rulers
- Markers for making charts
- Samples of products (Students can clip advertisements or print products off the internet. They need to have a picture of the product, explanation/details, price)

ESSENTIAL QUESTIONS

- How can I determine the unit rate for a product?
- How can I use unit rates to compare the value of products?
- How can my understanding of unit rates save me money?

OPENER/ACTIVATOR

Many educated consumers rely on unit pricing to make sure they are getting the best deal to fit their needs and budgets. We live in a society where we have a choice of purchasing countless consumer products. Just consider how many types of sneakers we can buy, or how many brands of potato chips from which we can choose.

Although most high school students are experienced consumers, they have not necessarily had a great deal of experience in making money-saving decisions. Engage students in a quick conversation to learn more about their shopping experience. Do they purchase the same product each time regardless of other options or do they think about which product would get them the most for their money? If they do consider other products, what strategies do they use to make the decision?

Explain that in today's lesson, students will get the opportunity to use mathematics to help them be a more informed consumer.

LESSON DESCRIPTION, DEVELOPMENT AND DISCUSSION

Lesson Directions:

Students will begin the project by selecting a product that can be packaged in three different sizes. For example, if the student chooses cola then they need to price it as a 6-pack, 12-pack, and 24-pack; each package needs to have the same number of ounces. Teachers can model this by bringing in examples of products with the same number of ounces, referring to vendor coupons, using printed ads, or surfing the web.

Some products and quantity/size to compare:

Soda
Potato Chips
Ice Cream
Milk
Paper products
Snack crackers

Students may need to be reminded to create a rough chart on scrap paper before attempting to draw their final copy. Encourage them to design a chart that will be informative, as well as easy to read.

An online site such as <http://www.netgrocer.com> is recommended. Make sure that students are not using a site in which the unit rates are already calculated.

Resource used for this lesson

Muschia, G. R. &, Muschia, J.A. (1996). *Hands-on math projects with real-life applications*. (pp. 126-130). New Jersey: Jossey-Bass.

FORMATIVE ASSESSMENT QUESTIONS

- How can you determine the cost of only one unit of the product?
- How much would you pay for only one unit of the product?
- How might you determine which size product is the better deal?

DIFFERENTIATION

Extension

For more difficult comparisons, ask students to compare products that may require some conversions. For instance, students can compare 2 liters of soda to cans of soda which are measured in ounces.

Intervention

Some students may be too overwhelmed by trying to find a product on the internet or in sales papers. For these students, provide some choices so that the focus can be placed on the mathematics and not on selecting products. Refer students to the *What is a Unit Rate?* lesson if they need assistance with finding unit rates.

For extra help with percentages, please open the hyperlink [Intervention Table](#).

CLOSING/SUMMARIZER

Students should display their work and present their findings to the class.

Name: _____

Project Due Date: _____



Which Is the Better Deal?

Situation/Problem

Your group is to select a product and compare the package size and price (three different sizes/prices). You are trying to determine which package is the best deal by finding each unit price. After you have reached your conclusions, design a chart to support your findings and be prepared to present your work to the class.

Your lesson

- + Decide on products to compare
 - Brainstorm with your group which products you might like to compare.
 - Look in sales papers for groceries/retail stores.
 - Look online at weekly ads for groceries/retail stores.

- + Decide which sizes or quantities you will compare
 - Any product packaged in more than one size can be compared.
 - Record your product and sizes/quantities on a piece of paper.

- + Compare the products
 - Compute unit rates.
 - Analyze results to determine the better deal.

- + Prepare for group presentation
 - Create a table illustrating results.
 - Prepare notes for presentation.
 - Assign each group member a responsibility for the presentation.
 - Rehearse your presentation.
 - Sketch your data

Be prepared to submit your chart after the presentation.

“Illustrative” Review 1

To review the concepts of percentages and rates, [Illustrative Mathematics](#) has many problem solving sets. Descriptions and links are provided below.

Teacher Note: These problems can be used each day of the module as opening problems or tickets-out-the-door.

1. **Rates of Change:** <https://www.illustrativemathematics.org/content-standards/6/RP/A/1/tasks/1181>
2. **Constant Rate:** <https://www.illustrativemathematics.org/content-standards/6/RP/A/2/tasks/1175>
3. **Unit Rates:** <https://www.illustrativemathematics.org/content-standards/6/RP/A/2/tasks/1611>
4. **Rates of Change:** <https://www.illustrativemathematics.org/content-standards/6/RP/A/3/tasks/134>
5. **Percentages:** <https://www.illustrativemathematics.org/content-standards/6/RP/A/3/tasks/118>
6. **Percentages:** <https://www.illustrativemathematics.org/content-standards/6/RP/A/3/tasks/1982>
7. **Percentages:** <https://www.illustrativemathematics.org/content-standards/6/RP/A/3/tasks/899>
8. **Percentages:** <https://www.illustrativemathematics.org/content-standards/6/RP/A/3/tasks/54>

The Variable Machine

Adapted from “The Variable Machine” on <http://illuminations.nctm.org/Lesson.aspx?id=1156>, retrieved on March 9, 2015.

SUGGESTED TIME FOR THIS LESSON:

Exact timings will depend on the needs of your class. Recommended timing is 90-120 minutes.

STANDARDS FOR MATHEMATICAL CONTENT

MFAEI1. Students will create and solve equations and inequalities in one variable.

- a. Use variables to represent an unknown number in a specified set (conceptual understanding of a variable). (MGSE6.EE.2, 5, 6)
- e. Use variables to solve real-world and mathematical problems. (MGSE6.EE.7, MGSE.7.EE.4)

STANDARDS FOR MATHEMATICAL PRACTICE

- 1. Make sense of problems and persevere in solving them.** Students will make sense of the problems to read, write and evaluate expressions.
- 2. Reason abstractly and quantitatively.** Students may be asked to reason through this lesson quantitatively using the variables assigned to each situation.
- 3. Construct viable arguments and critique the reasoning of others.** Students will share expressions and models with partners and discuss their reasonableness.
- 4. Model with mathematics.** Students will create expressions and equation models from scenarios.
- 6. Attend to precision.** Students will attend to precision through the use of the language of mathematics in their discussions as well as in the expressions they evaluate and write.
- 7. Look for and make use of structure.** Students will use the assigned variables to describe how the diner orders are related to the menu and write expressions showing this understanding.

EVIDENCE OF LEARNING/LEARNING TARGET

By the conclusion of this lesson, students should be able to:

- Use a variable to represent any member of a set of numbers.
- Replace variables with numbers to discover unknown values.

MATERIALS

- Two strips of lined notebook paper per student- one 5cm wide, one 3cm wide
- Transparent tape
- Student Handout: [Cracking the Code Activity Sheet](#)

ESSENTIAL QUESTIONS

- What is a variable?
- What does it mean “to vary”?
- What are different ways variables are presented in mathematical situations?
- How are variables used in real life?

OPENER/ACTIVATOR

Pose the following question to your students: Think of a situation where a group of people must have a common language. Then, make a list of “terms” that they would need to communicate with each other. For example: for baseball, you need to know specific terms like pitcher, outfield, bases, strike, batter...

Make the connection that with mathematics we also have a common language in which we use symbols to represent words or numbers. You can also introduce the term “conventions” as it appears in future lessons in this module.

LESSON

Tell the students they are going to create a variable machine to discover the value of words. On the 3-cm-wide strip of lined notebook paper, students should write the letters of the alphabet in order. On the 5-cm-wide strip of lined notebook paper, students should write the numbers 0 through 25. Then, they should attach the ends of the number strip together with tape, and wrap the letter strip around the number wheel and tape the ends together, matching letters to corresponding numbers: A to 0, B to 1, C to 2, etc. It may be helpful to show students a finished variable machine such as the one pictured below:

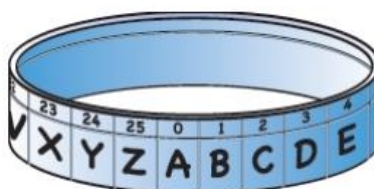

***Students can record their answers to the exploration questions on the Cracking the Code Activity sheet.*

For the first exploration, students should determine the value of their first names. For instance, the value of Tim’s name is 39: $T = 19$, $I = 8$, $M = 12$; so, $19 + 8 + 12 = 39$.

Students should then find the value of their last names, and answer the following questions:

- Which of your names has the higher value?
- What is the difference in the values of your first and last names?

Then, have students determine the value of the words variable, machine, algebra and mathematics as noted on the activity sheet.

Ask students to find words with the values 25, 36 and 100, and share their words with a neighbor.

After discussion of the words with the assigned values, ask them the following questions:

- *What is the three-letter word with the greatest value?*
- *Do you think the greatest values are always associated with words that contain the most letters?*
- *Determine a few words with more than ten letters whose values are less than the values of words with only three letters.*

INTERVENTION

For extra help with topics in this lesson, please refer to the [Intervention Table](#).

CLOSING/SUMMARIZER

Prompt students with the following questions:

- What is a variable?
- How did you use your Variable Machine to determine the value of your name?
- Do you think it is possible to change the values of each of the letters in a Variable Machine, or must they always be the same?

ADDITIONAL PRACTICE

Realign the number strips to let $A = 7$. Using this “new” Variable Machine, determine the value of your first name and your last name. Which is higher this time? *Responses will vary. It would be very useful to have students make a prediction prior to finding their answers.*

“Illustrative” Review 2

These checks may be used as formative assessments during the module to check student progress.

1. Writing Expressions: <https://www.illustrativemathematics.org/content-standards/6/EE/A/2/tasks/540>
2. Setting Up and Solving Equations: <https://www.illustrativemathematics.org/content-standards/7/EE/B/3/tasks/884>
3. Creating and Solving Inequalities: <https://www.illustrativemathematics.org/content-standards/7/EE/B/4/tasks/643>
4. More on Inequalities: <https://www.illustrativemathematics.org/content-standards/7/EE/B/4/tasks/986>
5. A More Challenging Inequality: <https://www.illustrativemathematics.org/content-standards/7/EE/B/4/tasks/1475>
6. More on Equations: <https://www.illustrativemathematics.org/content-standards/6/EE/B/6/tasks/425>
7. Setting Up and Solving Equations: <https://www.illustrativemathematics.org/content-standards/6/EE/B/7/tasks/1032>
8. Solving Basic Equations: <https://www.illustrativemathematics.org/content-standards/6/EE/B/7/tasks/1107>
9. Basic Inequalities: <https://www.illustrativemathematics.org/content-standards/6/EE/B/8>

Don't Sink My Battleship!

Adapted from *Teaching Student-Centered Mathematics Grades 5-8*, Van de Walle, John (2006).

SUGGESTED TIME FOR THIS LESSON:

Exact timings will depend on the needs of your class. Recommended timing is 120 minutes.

STANDARDS FOR MATHEMATICAL CONTENT

MFAEI2. Students will use units as a way to understand problems and guide the solutions of multi-step problems.

- a. Choose and interpret graphs and data displays, including the scale and comparisons of data. (MGSE3.MD.3, MGSE9-12.N.Q.1)
- b. Graph points in all four quadrants. (MGSE6.NS.8)

STANDARDS FOR MATHEMATICAL PRACTICE

1. Make sense of problems and persevere in solving them. Students make sense of problems involving points in the coordinate plane.

2. Reason abstractly and quantitatively. Students demonstrate abstract reasoning about positive and negative numbers with their visual representations.

3. Construct viable arguments and critique the reasoning of others. Students construct and critiques arguments regarding number line and coordinate plane representations.

4. Model with mathematics. Students use coordinate planes to model locations in real-world contexts.

6. Attend to precision. Students use the description of real-world situations to determine the appropriate location of points and what they represent.

7. Look for and make use of structure. Students relate the structure of number lines to positive and negative numbers as they use the coordinate plane.

EVIDENCE OF LEARNING/LEARNING TARGET

By the conclusion of this lesson, students should be able to:

- Locate ordered pairs on a coordinate grid.
- Create their own map and describe locations using the coordinate system.

MATERIALS

- Battleship game cards
- Student Handout: Grid City Spring Festival
- Graph paper or ruled chart paper

ESSENTIAL QUESTIONS

- When is graphing on the coordinate plane helpful?
- Why is the order of the coordinates important when graphing on the coordinate plane?

OPENER/ACTIVATOR

Show the students a blank coordinate grid. Define and discuss the origin of the coordinate grid, as well as how you determine locations within a coordinate system. Review the quadrants with the students, and have them graph a few ordered pairs as a quick pre-assessment. If necessary, revisit the earlier discussion on mathematical conventions to impress upon students the importance of having a consistent convention for the order of the coordinates.

LESSON

Distribute the [Don't Sink My Battleship!](#) game cards to the students.

Rules of the game: Players secretly put their initials on any five intersections of their own grid to denote the location of their ships. With the grids kept hidden from each other, one player takes a turn trying to “hit” the other player’s ships by naming a point on the grid using coordinates. The other player indicates whether or not it was a hit or a miss. Each player keeps track of where he has taken shots by recording an “X” for a hit and an “O” for a miss. When a player scores a hit, he or she gets another turn. The game ends when one player has hit all of the other player’s ships.

After playing Battleship, have the students work in pairs on the following lesson:

Grid City is getting ready for its spring festival! There will be 8 venues: arts and crafts, face painting, cotton candy and popcorn stand, barbecue pit, 2 bounce houses, a Playboxx station and a performance stage. These venues will need to be set up around the park. You must remember the following when designing your map:

- *The travel distance and proximity between venues*
- *The performance stage has to be positioned so that people can see it from any venue in the park.*
- *The barbecue pit should be 24 units away from the stage, and have the same y-coordinate.*

In the park, there will also be 6 port-a-potties, a ticket/information booth, and 4 sections of picnic tables.

- *The port-a-potties need to be set up on the left side of the park, all with the same x -coordinate.*
- *The ticket/information booth needs to be somewhere on the y -axis.*
- *The picnic table sections need to be spread out throughout the park.*

After students have completed their map, have each group display their maps and explain why they chose the placement of the venues.

INTERVENTION

For extra help with topics in this lesson, please refer to the [Intervention Table](#). For students who may really struggle with the Battleship Game, you could limit their game board to only two quadrants—try every combination (I and II, I and III, I and IV, etc.).

CLOSING/SUMMARIZER

Have the class generate numerous ideas for teaching the coordinate system to other students, including the use of mnemonic devices to remember that x is the horizontal component and y is the vertical component. Students should work in groups to come up with a three-part lesson made up of an opener, a lesson, and a closing.

ADDITIONAL PRACTICE

Students should present their three-part lesson on graphing in the coordinate plane to a fellow student or sibling. They should then summarize the strengths and weaknesses of their teaching experience and provide at least one “next step” if they were to keep teaching their “student.” *Responses/lessons will vary. Be sure to discuss what components should be included in the summary.*

Students never seem to tire of creating pictures on coordinate axes. Some holiday graphs can be found on http://www.math-aids.com/Graphing/Four_Quadrant_Graphing_Characters.html, or students can create their own.

Don't Sink My Battleship!

Battleship

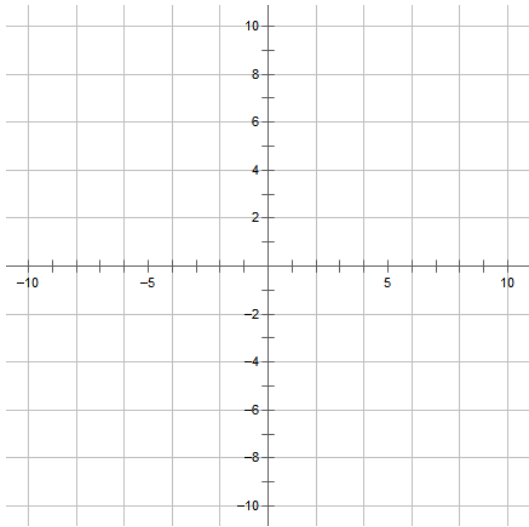

Battleship

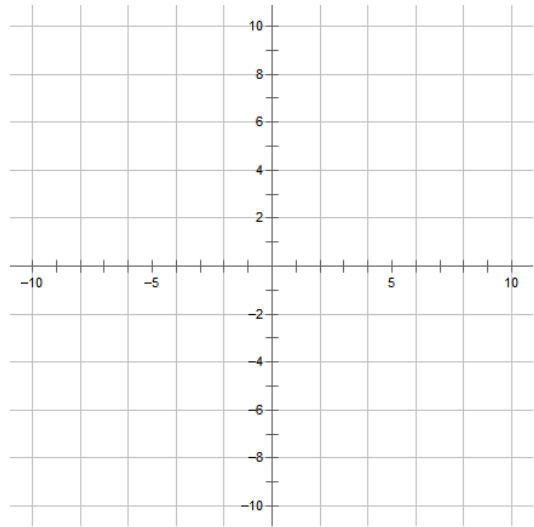

Battleship

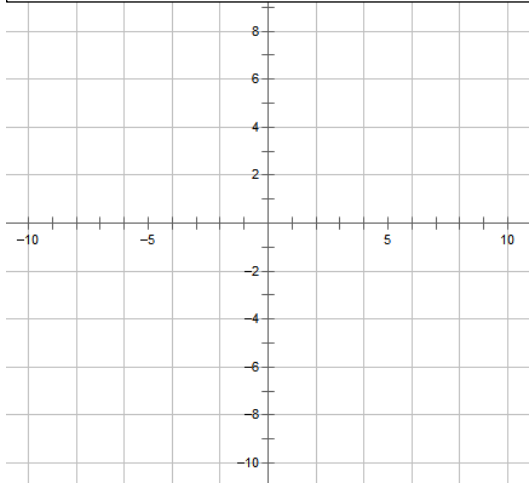

Battleship

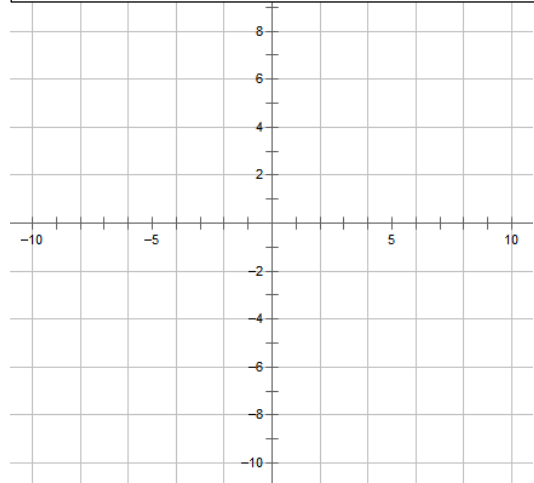

Student Handout: Grid City Spring Festival

Grid City is getting ready for its spring festival! There will be 8 venues: arts and crafts, face painting, cotton candy and popcorn stand, barbecue pit, 2 bounce houses, a Playboxx station and a performance stage. These venues will need to be set up around the park. You must remember the following when designing your map:

- The travel distance and proximity between venues
- The performance stage has to be positioned so that people can see it from any venue in the park.
- The barbecue pit should be 24 units away from the stage, and have the same y-coordinate.

In the park, there will also be 6 port-a-potties, a ticket/information booth, and 4 sections of picnic tables.

- The port-a-potties need to be set up on the left side of the park, all with the same x-coordinate.
- The ticket/information booth needs to be somewhere on the y-axis.
- The picnic table sections need to be spread out throughout the park.

APPENDIX OF RELEASED SAMPLE ASSESSMENT ITEMS

The following released assessment items correspond to sixth grade standards.

TEACHER'S EDITION

*Released item from 6th grade Louisiana Math 2014

1. Brianna's teacher asked her which of these three expressions are equivalent to each other:

Expression A: $9x - 3x - 4$

Expression B: $12x - 4$

Expression C: $5x + x - 4$

Brianna says that all three expressions are equivalent because the value of each one is -4 when $x = 0$.

Brianna's thinking is incorrect.

Identify the error in Brianna's thinking. *Brianna was confusing substitution with simplifying.*

Determine which of the three expressions are equivalent. *A and C*

Explain or show your process in determining which expressions are equivalent. *A and C are both equivalent to $6x - 4$*

*released item from Smarter Balanced 7th grade 7.EE.A.1

2. Find the value of p so the expression $\frac{5}{6} - \frac{1}{3}n$ is equivalent to $p(5 - 2n)$.

$$p = \frac{1}{6}$$

*Released item from North Carolina End of Grade 7 2013

3. Angie has a bag containing n apples. She gives 4 to her brother and keeps 5 for herself. She then divides the remaining apples equally among 3 friends.

Which of the following expressions represents the number of apples each friend receives?

A. $\frac{n}{3} - 4 - 5$

B. $\frac{n - 4 - 5}{3}$

C. $\frac{4 + 5 - n}{3}$

D. $\frac{n - 4}{3} - 5$

E. $\frac{n - 5}{3} - 4$

B

*Released item from NAEP 2009

4. What is the value of $-2\left(4^2 + \left(\frac{1}{2}\right)^2\right)$? Show all steps that lead to your response.

-2 (16 + ¼)

-2 (16.25)

-32.50

*6th grade Louisiana

5. The formula for finding the surface area of a sphere that has a radius r is shown in the box below.

$$SA = 4\pi r^2$$

A baseball has a diameter of 74 cm. Find that surface area of the baseball rounded to the nearest whole number when using 3.14 for π .

17,195 square units

6. 8th grade Massachusetts

A stained glass window is in the shape of a square. A sketch of the window with some of its dimensions is shown below

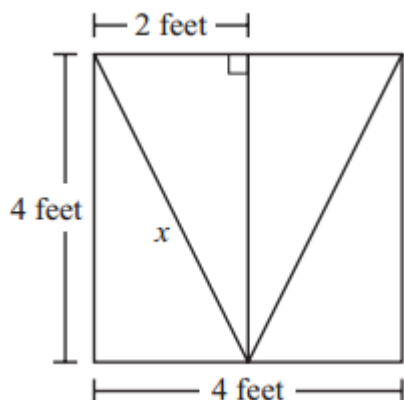

What is the length, to the nearest tenth of a foot, of the line segment labeled x ?

4 feet

The following are from released items and practice problems from Georgia's End of Course Tests.

7. The dimensions of a rectangle are shown. What is the perimeter of the rectangle?

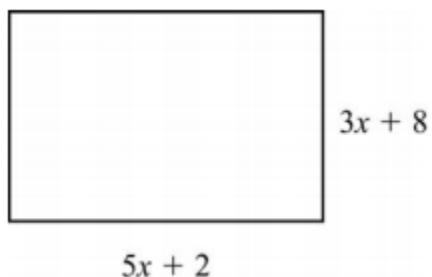

Solution:

Substitute $5x + 2$ for l and $3x + 8$ for w into the formula for the perimeter of a rectangle:

$$P = 2l + 2w$$

$$P = 2(5x + 2) + 2(3x + 8)$$

$$P = 10x + 4 + 6x + 16$$

$$P = 16x + 20$$

8. A model of a house is shown. What is the perimeter of the model?

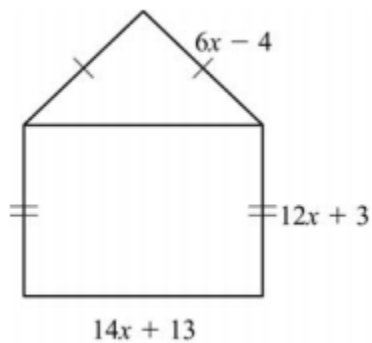

$$50x + 11$$

9. A rectangular field is 100 meters in width and 120 meters in length. The dimensions of the field will be expanded by x meters in each direction, as shown in the diagram. Write an expression for the perimeter of the new field in terms of x .

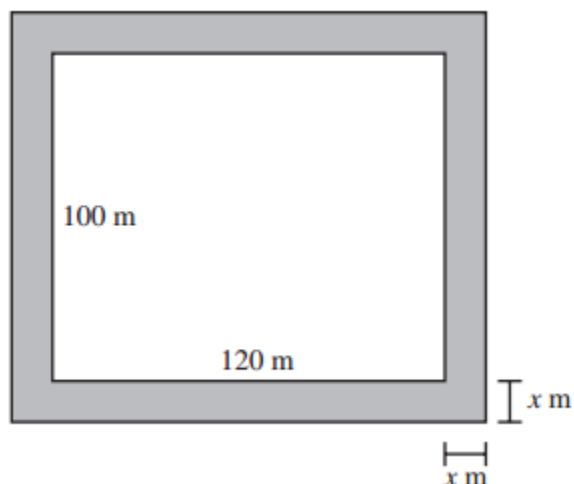

$440 + 4x$

10. The diagram shows the dimensions of a cardboard box. Write an expression to represent the volume of the box.

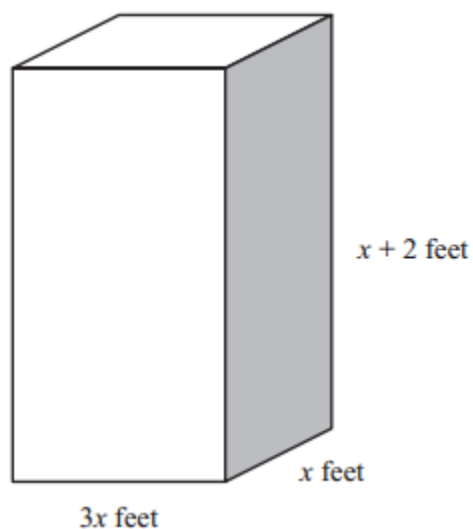

$3x * x(x + 2) = 3x^3 + 6x^2$

STUDENT'S EDITION

*Released item from 6th grade Louisiana Math 2014

1. Brianna's teacher asked her which of these three expressions are equivalent to each other:

Expression A: $9x - 3x - 4$

Expression B: $12x - 4$

Expression C: $5x + x - 4$

Brianna says that all three expressions are equivalent because the value of each one is -4 when $x = 0$.

Brianna's thinking is incorrect.

Identify the error in Brianna's thinking.

Determine which of the three expressions are equivalent.

Explain or show your process in determining which expressions are equivalent.

*released item from Smarter Balanced 7th grade 7.EE.A.1

2. Find the value of p so the expression $\frac{5}{6} - \frac{1}{3}n$ is equivalent to $p(5 - 2n)$.

*Released item from North Carolina End of Grade 7 2013

3. Angie has a bag containing n apples. She gives 4 to her brother and keeps 5 for herself. She then divides the remaining apples equally among 3 friends.

Which of the following expressions represents the number of apples each friend receives?

A. $\frac{n}{3} - 4 - 5$

B. $\frac{n - 4 - 5}{3}$

C. $\frac{4 + 5 - n}{3}$

D. $\frac{n - 4}{3} - 5$

E. $\frac{n - 5}{3} - 4$

Georgia Department of Education
Georgia Standards of Excellence Middle School Support
GSE Grade 6 • Connections/Support Materials for Remediation

*Released item from NAEP 2009

4. What is the value of $-2\left(4^2 + \left(\frac{1}{2}\right)^2\right)$? Show all steps that lead to your response.

*6th grade Louisiana

5.

The formula for finding the surface area of a sphere that has a radius r is shown in the box below

$$SA = 4\pi r^2$$

A baseball has a diameter of 74 cm. Find that surface area of the baseball rounded to the nearest whole number when using 3.14 for π .

6. 8th grade Massachusetts

A stained glass window is in the shape of a square. A sketch of the window with some of its dimensions is shown below

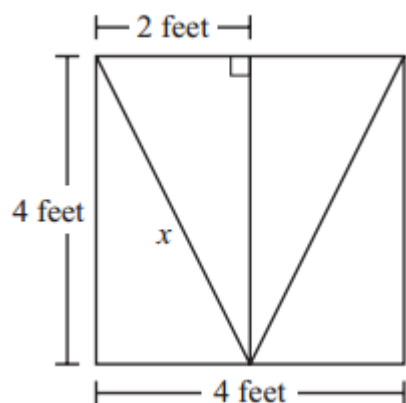

What is the length, to the nearest tenth of a foot, of the line segment labeled x ?

The following are from released items and practice problems from Georgia's End of Grade Tests.

7. The dimensions of a rectangle are shown. What is the perimeter of the rectangle?

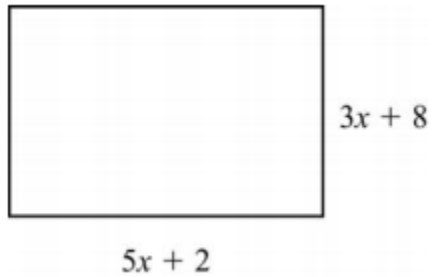

8. A model of a house is shown. What is the perimeter of the model?

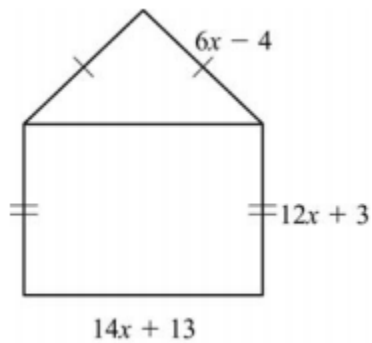

Georgia Department of Education
Georgia Standards of Excellence Middle School Support
GSE Grade 6 • Connections/Support Materials for Remediation

9. A rectangular field is 100 meters in width and 120 meters in length. The dimensions of the field will be expanded by x meters in each direction, as shown in the diagram. Write an expression for the perimeter of the new field in terms of x .

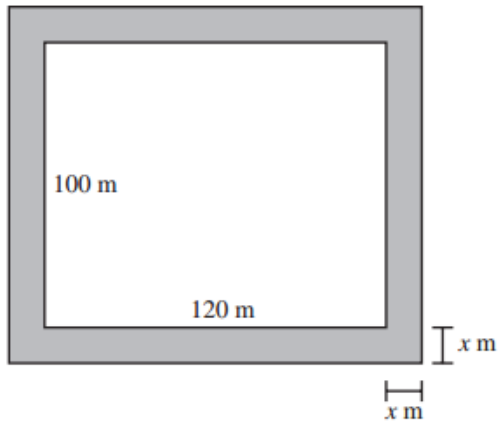

10. The diagram shows the dimensions of a cardboard box. Write an expression to represent the volume of the box.

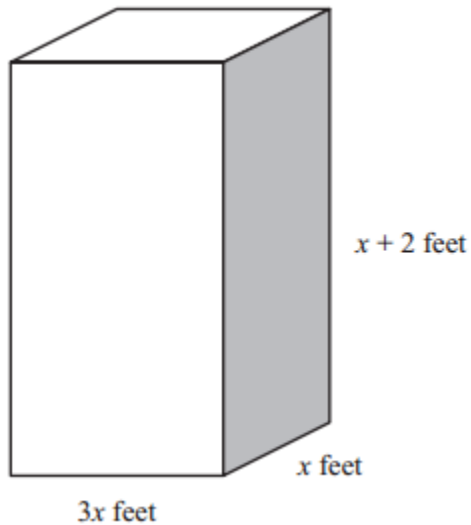

WEB LINKS

The following websites are correlated to the designated 6th grade standards.

Unit 1

MGSE6.NS.1 Interpret and compute quotients of fractions, and solve word problems involving division of fractions by fractions, including reasoning strategies such as using visual fraction models and equations to represent the problem.

For example:

How much chocolate will each person get if 3 people share $\frac{1}{2}$ lb of chocolate equally?

How many $\frac{3}{4}$ -cup servings are in $\frac{2}{3}$ of a cup of yogurt?

How wide is a rectangular strip of land with length $\frac{3}{4}$ mi and area $\frac{1}{2}$ square mi?

Three pizzas are cut so each person at the table receives $\frac{1}{4}$ pizza. How many people are at the table?

Create a story context for $(\frac{2}{3}) \div (\frac{3}{4})$ and use a visual fraction model to show the quotient;

Use the relationship between multiplication and division to explain that $(\frac{2}{3}) \div (\frac{3}{4}) = \frac{8}{9}$ because $\frac{3}{4}$ of $\frac{8}{9}$ is $\frac{2}{3}$. (In general, $(\frac{a}{b}) \div (\frac{c}{d}) = \frac{ad}{bc}$)

<https://www.illustrativemathematics.org/content-standards/6/NS/A/1/tasks>

<http://www.visualfractions.com/divide.htm>

<http://www.yummymath.com/wp-content/uploads/fathers-day-muffins.pdf>

<http://www.openmiddle.com/dividing-fractions/>

<http://www.openmiddle.com/dividing-mixed-numbers/>

<http://www.openmiddle.com/undefined-products-with-fraction-division/>

<http://www.101qs.com/3043>

<http://nzmaths.co.nz/resource/dividing-fractions>

<http://nzmaths.co.nz/resource/dividing-fractions-0>

<http://www.pbslearningmedia.org/resource/mgbh.math.nf.lindadiv/division-of-fractions/>

Compute fluently with multi-digit numbers and find common factors and multiples

MGSE6.NS.2 Fluently divide multi-digit numbers using the standard algorithm.

http://www.pbslearningmedia.org/asset/mgbh_int_divmodel/

MGSE6.NS.3 Fluently add, subtract, multiply, and divide multi-digit decimals using the standard algorithm for each operation.

<http://mtorgrude.tie.wikispaces.net/file/view/MakingSenseofDecimalMultiplication.pdf>

MGSE6.NS.4 Find the common multiples of two whole numbers less than or equal to 12 and the common factors of two whole numbers less than or equal to 100.

Find the greatest common factor of 2 whole numbers and use the distributive property to express a sum of two whole numbers 1-100 with a common factor as a multiple of a sum of two whole numbers with no common factors. (GCF) *Example:* $36 + 8 = 4(9 + 2)$

Apply the least common multiple of two whole numbers less than or equal to 12 to solve real-world problems.

<http://www.rda.aps.edu/mathtaskbank/pdfs/tasks/6-8/t68gears.pdf>

http://www.learner.org/courses/learningmath/number/session6/part_a/area.html

Unit 2

MGSE6.RP.1 Understand the concept of a ratio and use ratio language to describe a ratio relationship between two quantities.

<https://www.illustrativemathematics.org/content-standards/6/RP/A/1/tasks>

<http://nzmaths.co.nz/resource/ratios-and-rates>

<http://www.bbc.co.uk/schools/mathsfilm/shockwave/games/fish.html>

<http://mathsnacks.com/baddate-en.html>

MGSE6.RP.2 Understand the concept of a unit rate a/b associated with a ratio $a:b$ with $b \neq 0$ (b not equal to zero), and use rate language in the context of a ratio relationship.

<https://www.illustrativemathematics.org/content-standards/6/RP/A/2/tasks>

<http://illuminations.nctm.org/Lesson.aspx?id=1110>

<http://nzmaths.co.nz/resource/ratios-and-rates>

<http://mathsnacks.com/baddate-en.html>

MGSE6.RP.3 Use ratio and rate reasoning to solve real-world and mathematical problems utilizing strategies such as tables of equivalent ratios, tape diagrams (bar models), double number line diagrams, and/or equations.

<http://www.learner.org/courses/learningmath/number/support/lmg8.pdf>

<https://www.illustrativemathematics.org/content-standards/6/RP/A/3/tasks>

<http://illuminations.nctm.org/Lesson.aspx?id=1658>

<http://illuminations.nctm.org/Lesson.aspx?id=2534>

[Understanding Tape Diagrams and Double Number Lines](#) (Teacher Link)

[Understanding Tape Diagrams](#) (Teacher Link)

<http://mathsnacks.com/baddate-en.html>

Dan Meyer:

<http://www.101qs.com/2841-nanas-paint-mixup>

<http://threeacts.mrmeyer.com/sugarpackets/>

<http://threeacts.mrmeyer.com/leakyfaucet/>

Georgia Department of Education
Georgia Standards of Excellence Middle School Support
GSE Grade 6 • Connections/Support Materials for Remediation

<http://threeacts.mrmeyer.com/nana/>
<http://mrmeyer.com/threeacts/superbear/>
<http://mrmeyer.com/threeacts/showervbath/>
<http://mrmeyer.com/threeacts/printjob/>
<http://threeacts.mrmeyer.com/splittime/>

Estimation180:

<http://www.estimation180.com/day-127.html>
<http://www.estimation180.com/day-128.html>
<http://www.estimation180.com/day-129.html>
<http://www.estimation180.com/day-130.html>
<http://www.estimation180.com/day-131.html>
<http://www.estimation180.com/day-132.html>
<http://www.estimation180.com/day-133.html>
<http://www.estimation180.com/day-134.html>

MGSE6.RP.3a Make tables of equivalent ratios relating quantities with whole number measurements, find missing values in tables, and plot the pairs of values on the coordinate plane. Use tables to compare ratios.

PARCC Prototype Task: [Gasoline Consumption](#)

MGSE6.RP.3b Solve unit rate problems including those involving unit pricing and constant speed.

MGSE6.RP.3c Find a percent of a quantity as a rate per 100 (e.g. 30% of a quantity means 30/100 times the quantity); given a percent, solve problems involving finding the whole given a part and the part given the whole.

NCTM Illuminations:

<http://illuminations.nctm.org/Lesson.aspx?id=1049>
<http://illuminations.nctm.org/Lesson.aspx?id=3170>
<http://illuminations.nctm.org/Lesson.aspx?id=960>

NZmaths:

<http://nzmaths.co.nz/search/node/percents>

OpenMiddle:

<http://www.openmiddle.com/interpreting-percentages/>

Estimation180:

<http://www.estimation180.com/day-129.html>
<http://www.estimation180.com/day-130.html>

MGSE6.RP.3d Given a conversion factor, use ratio reasoning to convert measurement units within one system of measurement and between two systems of measurements (customary and metric); manipulate and transform units appropriately when multiplying or dividing quantities. *For example, given $1 \text{ in.} = 2.54 \text{ cm}$, how many centimeters are in 6 inches?*

OpenMiddle:

<http://www.openmiddle.com/converting-between-fahrenheit-and-celsius/>

PARCC Prototype Item: [Slide Ruler](#)

[How Many Football Fields is 10 Miles?](#) by Andrew Stadel

Unit 3

MGSE6.EE.1 Write and evaluate expressions involving whole-number exponents.

<https://www.illustrativemathematics.org/content-standards/6/EE/A/1/tasks/532>
<https://www.illustrativemathematics.org/content-standards/6/EE/A/1/tasks/891>
<https://www.illustrativemathematics.org/content-standards/6/EE/A/1/tasks/1523>
<http://www.openmiddle.com/order-of-operations-3/>
<http://www.openmiddle.com/order-of-operations-2/>
<http://www.openmiddle.com/order-of-operations/>
<http://nzmaths.co.nz/resource/four-fours-challenge>

MGSE6.EE.2 Write, read, and evaluate expressions in which letters stand for numbers.

<https://www.illustrativemathematics.org/content-standards/6/EE/A/2/tasks/421>
<https://www.illustrativemathematics.org/content-standards/6/EE/A/2/tasks/540>

MGSE6.EE.2a Write expressions that record operations with numbers and with letters standing for numbers. *For example, express the calculation “Subtract y from 5” as $5-y$.*

MGSE6.EE.2b Identify parts of an expression using mathematical terms (sum, term, product, factor, quotient, coefficient); view one or more parts of an expression as a single entity. For example, describe the expression $2(8 + 7)$ as a product of two factors; view $(8 + 7)$ as both a single entity and a sum of two terms.

<http://nzmaths.co.nz/resource/cup-capers>

MGSE6.EE.2c Evaluate expressions at specific values of their variables. Include expressions that arise from formulas used in real-world problems. Perform arithmetic operations, including those involving whole-number exponents, in the conventional order when there are no parentheses to specify a particular order (Order of Operations). For example, use the formulas $V = s^3$ and $A = 6s^2$ to find the volume and surface area of a cube with sides of length $s = \frac{1}{2}$.

MGSE6.EE.3 Apply the properties of operations to generate equivalent expressions. *For example, apply the distributive property to the expression $3(2 + x)$ to produce the equivalent*

expression $6 + 3x$; apply the distributive property to the expression $24x + 18y$ to produce the equivalent expression $6(4x + 3y)$; apply properties of operations to $y + y + y$ to produce the equivalent expression $3y$.

<https://www.illustrativemathematics.org/content-standards/6/EE/A/3/tasks/997>

<http://www.openmiddle.com/product-of-distributive-property/>

<http://www.pbslearningmedia.org/resource/mgbh.math.nf.commprop/commutative-and-associative-equations/>

http://media.mivu.org/mvu_pd/a4a/homework/applets_multiplication.html

<http://illuminations.nctm.org/Lesson.aspx?id=2682>

https://www.teachervision.com/tv/printables/0134356500_M1MUTM27.pdf

MGSE6.EE.4 Identify when two expressions are equivalent (i.e., when the two expressions name the same number regardless of which value is substituted into them.) *For example, the expressions $y + y + y$ and $3y$ are equivalent because they name the same number regardless of which number y stands for.*

<https://www.illustrativemathematics.org/content-standards/6/EE/A/4/tasks/461>

<https://www.illustrativemathematics.org/content-standards/6/EE/A/4/tasks/542>

http://www.learner.org/courses/learningmath/algebra/session6/part_c/index.html

<http://illuminations.nctm.org/activity.aspx?id=3529>

MGSE6.NS.4 Find the common multiples of two whole numbers less than or equal to 12 and the common factors of two whole numbers less than or equal to 100.

Find the greatest common factor of 2 whole numbers and use the distributive property to express a sum of two whole numbers 1-100 with a common factor as a multiple of a sum of two whole numbers with no common factors. (GCF) *Example: $36 + 8 = 4(9 + 2)$*

Apply the least common multiple of two whole numbers less than or equal to 12 to solve real-world problems.

<https://illuminations.nctm.org/Activity.aspx?id=3530>

<http://www.rda.aps.edu/mathtaskbank/pdfs/tasks/6-8/t68gears.pdf>

http://www.learner.org/courses/learningmath/number/session6/part_a/area.html

Unit 4

MGSE6.EE.9 Use variables to represent two quantities in a real-world problem that change in relationship to one another.

Write an equation to express one quantity, the dependent variable, in terms of the other quantity, the independent variable.

Analyze the relationship between the dependent and independent variables using graphs and tables, and relate these to the equation. *For example, in a problem involving motion at constant speed, list and graph ordered pairs of distances and times, and write the equation $d = 65t$ to represent the relationship between distance and time.*

<https://www.illustrativemathematics.org/content-standards/6/EE/C/9/tasks/806>

http://ccsstoolbox.agilemind.com/parcc/middle_3788_1.html
http://ccsstoolbox.agilemind.com/parcc/middle_3789_1.html
http://www.colmanweb.co.uk/Assets/SWF/Skate_boarders.swf
<http://www.absorblearning.com/media/attachment.action?quick=wl&att=2335>
<http://www.explorelearning.com/index.cfm?method=cResource.dspView&ResourceID=260>

Unit 5

MGSE6.G.1 Find area of right triangles, other triangles, quadrilaterals, and polygons by composing into rectangles or decomposing into triangles and other shapes; apply these techniques in the context of solving real-world and mathematical problems.

<https://www.illustrativemathematics.org/content-standards/6/G/A/1/tasks/509>
<https://www.illustrativemathematics.org/content-standards/6/G/A/1/tasks/510>
<https://www.illustrativemathematics.org/content-standards/6/G/A/1/tasks/647>
<https://www.illustrativemathematics.org/content-standards/6/G/A/1/tasks/656>
<https://www.illustrativemathematics.org/content-standards/6/G/A/1/tasks/1523>
<https://www.illustrativemathematics.org/content-standards/6/G/A/1/tasks/1993>
<http://threeacts.mrmeyer.com/bubblewrap/>
<http://illuminations.nctm.org/ActivityDetail.aspx?ID=108>
<http://www.geogebra.org/en/upload/files/english/Victoria/TriangleArea.html>
<http://www.geogebra.org/en/upload/files/english/Knote/Area/parallelograms.html>
<http://www.geogebra.org/en/upload/files/english/Knote/Area/Parallelogram2.html>
<http://illuminations.nctm.org/LessonDetail.aspx?ID=L583>
<http://illuminations.nctm.org/LessonDetail.aspx?ID=U160>
<http://www.shodor.org/interactivate/activities/AreaExplorer>
http://nlvm.usu.edu/en/nav/frames_asid_129_g_3_t_3.html?open=activities&from=category_g_3_t_3.html

MGSE6.G.2 Find the volume of a right rectangular prism with fractional edge lengths by packing it with unit cubes of the appropriate unit fraction edge lengths ($\frac{1}{2}$ u), and show that the volume is the same as would be found by multiplying the edge lengths of the prism. Apply the formulas $V = (\text{length}) \times (\text{width}) \times (\text{height})$ and $V = (\text{area of base}) \times (\text{height})$ to find volumes of right rectangular prisms with fractional edge lengths in the context of solving real-world and mathematical problems.

<https://www.illustrativemathematics.org/content-standards/6/G/A/2/tasks/534>
<https://www.illustrativemathematics.org/content-standards/6/G/A/2/tasks/535>
<https://www.illustrativemathematics.org/content-standards/6/G/A/2/tasks/536>
<https://www.illustrativemathematics.org/content-standards/6/G/A/2/tasks/537>
<http://www.shodor.org/interactivate/activities/SurfaceAreaAndVolume/>
<http://illuminations.nctm.org/ActivityDetail.aspx?ID=6>

MGSE6.G.4 Represent three-dimensional figures using nets made up of rectangles and triangles, and use the nets to find the surface area of these figures. Apply these techniques in the context of solving real-world and mathematical problems.

<https://www.illustrativemathematics.org/content-standards/6/G/A/4/tasks/1985>
<http://www.101qs.com/3038>
<http://www.estimation180.com/filecabinet.html>
<http://mr-stadel.blogspot.com/2014/05/fun-with-sticky.html>
<http://www.openmiddle.com/maximizing-rectangular-prism-surface-area/>
<http://www.openmiddle.com/rectangular-prism-surface-area-versus-volume/>
<http://www.openmiddle.com/rectangular-prism-surface-area/>
<http://www.shodor.org/interactivate/activities/SurfaceAreaAndVolume/>
<http://illuminations.nctm.org/Activity.aspx?id=4182>

Unit 6

Develop understanding of statistical variability.

http://illuminations.nctm.org/Search.aspx?view=search&cc=2059_2107

MGSE6.SP.1. Recognize a statistical question as one that anticipates variability in the data related to the question and accounts for it in the answers. For example, “How old am I?” is not a statistical question, but “How old are the students in my school?” is a statistical question because one anticipates variability in students’ ages.

<https://www.illustrativemathematics.org/content-standards/6/SP/A/1/tasks/703>
<https://www.illustrativemathematics.org/content-standards/6/SP/A/1/tasks/1040>
<https://www.illustrativemathematics.org/content-standards/6/SP/A/1/tasks/2008>

MGSE6.SP.2. Understand that a set of data collected to answer a statistical question has a distribution which can be described by its center, spread, and overall shape.

<https://www.illustrativemathematics.org/content-standards/6/SP/A/2/tasks/1199>
<https://www.illustrativemathematics.org/content-standards/6/SP/A/2/tasks/2043>
<https://www.illustrativemathematics.org/content-standards/6/SP/A/2/tasks/1026>
<https://www.illustrativemathematics.org/content-standards/6/SP/A/2/tasks/2100>

MGSE6.SP.3 Recognize that a measure of center for a numerical data set summarizes all of its values with a single number, while a measure of variation describes how its values vary with a single number.

<https://www.illustrativemathematics.org/content-standards/6/SP/A/3/tasks/2097>
http://www.learner.org/courses/learningmath/data/session5/part_c/balancing.html
<http://www.shodor.org/interactivate/lessons/IntroStatistics/>
<http://www.shodor.org/interactivate/activities/PlopIt/>

Summarize and describe distributions.

MGSE6.SP.4. Display numerical data in plots on a number line, including dot plots, histograms, and box plots.

<https://www.illustrativemathematics.org/content-standards/6/SP/B/4/tasks/877>
<https://www.illustrativemathematics.org/content-standards/6/SP/B/4/tasks/2043>
<https://www.illustrativemathematics.org/content-standards/6/SP/B/4/tasks/2047>
<https://www.illustrativemathematics.org/content-standards/6/SP/B/4/tasks/1026>
<https://www.illustrativemathematics.org/content-standards/6/SP/B/4/tasks/2100>
http://www.learner.org/courses/learningmath/data/session4/part_d/drawing.html
<http://illuminations.nctm.org/Activity.aspx?id=3476>
<http://illuminations.nctm.org/lesson.aspx?id=1688>

MGSE6.SP.5 Summarize numerical data sets in relation to their context, such as by:

- a. Reporting the number of observations.
- b. Describing the nature of the attribute under investigation, including how it was measured and its units of measurement.
- c. Giving quantitative measures of center (median and/or mean) and variability (interquartile range).

<https://www.illustrativemathematics.org/content-standards/6/SP/B/5/tasks/877>
<https://www.illustrativemathematics.org/content-standards/6/SP/B/5/tasks/2043>
<https://www.illustrativemathematics.org/content-standards/6/SP/B/5/tasks/2047>
<https://www.illustrativemathematics.org/content-standards/6/SP/B/5/tasks/2054>
<http://www.openmiddle.com/lower-and-upper-quartiles-with-constraints/>
<http://www.openmiddle.com/median-with-constraints/>
<http://www.openmiddle.com/mean-median-and-range/>

- d. Relating the choice of measures of center and variability to the shape of the data distribution and the context in which the data was gathered.

<https://www.illustrativemathematics.org/content-standards/6/SP/B/5/tasks/1199>
<https://www.illustrativemathematics.org/content-standards/6/SP/B/5/tasks/2048>

Unit 7

Apply and extend previous understandings of numbers to the system of rational numbers.

MGSE6.NS.5 Understand that positive and negative numbers are used together to describe quantities having opposite directions or values (e.g., temperature above/below zero, elevation above/below sea level, debits/credits, positive/negative electric charge); use positive and negative numbers to represent quantities in real-world contexts, explaining the meaning of 0 in each situation.

<https://www.illustrativemathematics.org/content-standards/6/NS/C/5/tasks/277>
<https://www.illustrativemathematics.org/content-standards/6/NS/C/5/tasks/278>
<http://figurethis.nctm.org/challenges/c46/challenge.htm>

MGSE6.NS.6 Understand a rational number as a point on the number line. Extend number line diagrams and coordinate axes familiar from previous grades to represent points on the line and in the plane with negative number coordinates.

<https://www.illustrativemathematics.org/content-standards/6/NS/C/6/tasks/1665>
<https://www.illustrativemathematics.org/content-standards/6/NS/C/6/tasks/1998>
<https://www.illustrativemathematics.org/content-standards/6/NS/C/6/tasks/1999>
<https://www.illustrativemathematics.org/content-standards/6/NS/C/6/tasks/2009>
<http://www.shodor.org/interactivate/activities/GeneralCoordinates/>
<https://www.mathsisfun.com/data/cartesian-coordinates-interactive.html>
<http://www.explore.math.com/school/subject2/practice/S2U4L1/S2U4L1Pract.html>
<http://www.oswego.org/ocsd-web/games/BillyBug2/bug2.html>
http://ccsstoobox.agilemind.com/parcc/middle_1.html

MGSE6.NS.6a Recognize opposite signs of numbers as indicating locations on opposite sides of 0 on the number line; recognize that the opposite of the opposite of a number is the number itself, e.g., $-(-3) = 3$, and that 0 is its own opposite.

MGSE6.NS.6b Understand signs of number in ordered pairs as indicating locations in quadrants of the coordinate plane; recognize that when two ordered pairs differ only by signs, the locations of the points are related by reflections across one or both axes.

<http://mr-stadel.blogspot.com/2014/01/fun-with-dot-and-line.html>

MGSE6.NS.6c Find and position integers and other rational numbers on a horizontal or vertical number line diagram; find and position pairs of integers and other rational numbers on a coordinate plane.

MGSE6.NS.7 Understand ordering and absolute value of rational numbers.

<https://www.illustrativemathematics.org/content-standards/6/NS/C/7/tasks/283>
<https://www.illustrativemathematics.org/content-standards/6/NS/C/7/tasks/284>
<https://www.illustrativemathematics.org/content-standards/6/NS/C/7/tasks/285>
<https://www.illustrativemathematics.org/content-standards/6/NS/C/7/tasks/286>
<https://www.illustrativemathematics.org/content-standards/6/NS/C/7/tasks/288>
http://ccsstoobox.agilemind.com/parcc/middle_1.html

MGSE6.NS.7a Interpret statements of inequality as statements about the relative position of two numbers on a number line diagram.

<http://www.yummymath.com/2014/weather-extremes/>

MGSE6.NS.7b Write, interpret, and explain statements of order for rational numbers in real-world contexts.

MGSE6.NS.7c Understand the absolute value of a rational number as its distance from 0 on the number line; interpret absolute value as magnitude for a positive or negative quantity in a real-world situation.

MGSE6.NS.7d Distinguish comparisons of absolute value from statements about order.

MGSE6.NS.8 Solve real-world and mathematical problems by graphing points in all four quadrants of the coordinate plane. Include use of coordinates and absolute value to find distances between points with the same first coordinate or the same second coordinate.

<https://www.illustrativemathematics.org/content-standards/6/NS/C/8/tasks/290>

Solve real-world and mathematical problems involving area, surface area, and volume.

MGSE6.G.3. Draw polygons in the coordinate plane given coordinates for the vertices; use coordinates to find the length of a side joining points with the same first coordinate or the same second coordinate. Apply those techniques in the context of solving real-world mathematical problems.

<https://www.illustrativemathematics.org/content-standards/6/G/A/3/tasks/1188>

<https://www.illustrativemathematics.org/content-standards/6/G/A/3/tasks/1997>

<http://illuminations.nctm.org/Lesson.aspx?id=1089>

ADDITIONAL RESOURCES

- Georgiastandards.org provides a gateway to a wealth of instruction links and information. Open the GSE Mathematics to access specific GSE resources for this course.
- [Georgia Virtual School](#) content available on the Shared Resources Website is available for anyone to view. Courses are divided into modules and are aligned with the Georgia Standards of Excellence.
- [Course/Grade Level WIKI](#) spaces are available to post questions about a unit, a standard, the course, or any other GSE mathematics related concern. Shared resources and information are also available at the site.
- From the National Council of Teachers of Mathematics, Illuminations: [Height of Students in our Class](#). This lesson has students creating box-and-whisker plots with an extension of finding measures of center and creating a stem-and-leaf plot.
- [National Library of Virtual Manipulatives](#). Students can use the appropriate applet from this page of virtual manipulatives to create graphical displays of the data set. This provides an important visual display of the data without the tediousness of the student hand drawing the display.
- Kader, Gary D. “Means and MADs.” *Mathematics Teaching in the Middle School* 4.6 (1999): 398-403. Print.
- Franklin, C., Kader, G., Mewborne, D., Moreno, J., Peck, R., Perry, M., Scheaffer, R. (2007). *Guidelines for assessment and instruction in statistics education (gaise) report: A pre-k-12 curriculum framework*. Alexandria, Virginia: American Statistical Association. Print.
- Bright, G., Brewer, W., McClain, K., and Mooney, E. (2001). [Navigating Through Data Analysis in Grades 6-8](#). Reston, VA: NCTM.
- [Statistics and Probability \(Grades 6-9\)](#). Activities that Integrate Math and Science (AIMS Foundation).
- Number Talks for Middle School: http://mathematicssolutions.com/wp-content/uploads/14_nctm_kcohen_numbertalks.pdf